



**Istituto per le Tecnologie
della Costruzione
Consiglio Nazionale delle Ricerche**

Via Lombardia 49 - 20098 San Giuliano Milanese – Italy
tel: +39-02-9806.1 – Telefax: +39-02-98280088
e-mail: segreteria.itab@itc.cnr.it



Member of



www.eota.eu
European Organisation for
Technical Assessment
Organisation Européenne
pour l'évaluation technique

European Technical Assessment ETA 17/0869 of 19/04/2023

GENERAL PART

Trade name of the construction product	GL LOCATELLI anchor channels (GP) with channel bolts (V) and smart anchor channels (HGP)
Product family to which the construction product belongs	PAC 33: FIXINGS. Anchor channels
Manufacturer	GL Locatelli S.r.l Via Dante Alighieri, 66 22078 Turate (CO) - Italy
Manufacturing plant	GL Locatelli S.r.l Via Dante Alighieri, 66 22078 Turate (CO) - Italy
This European Technical Assessment contains:	32 pages, including 17 annexes which form an integral part of this assessment
This European Technical Assessment is issued in accordance with Regulation (EU) n° 305/2011, on the basis of	EAD 330008-03-0601 – Anchor Channels
This version replaces	ETA 17/0869 (version 03) of 18/03/2022

The European Technical Assessment is issued by ITC-CNR in English language. Translations of this European Technical Assessment into other languages shall fully correspond to the original issued document and should be identified as such. Communication of this European Technical Assessment, including transmission by electronic means, shall be in full (excepted the confidential Annex(es) referred to above). However, partial reproduction can be made with the written consent of ITC-CNR (issuing Technical Assessment Body). In this case partial reproduction has to be designated as such.

SPECIFIC PARTS

1. TECHNICAL DESCRIPTION OF THE PRODUCT

GP40/223 – HGP40/223 – GP50/30 – HGP50/30 – GP54/33 – HGP54/33 anchor channels consist of C-shaped channel of cold-formed steel, and at least two steel anchors non-detachably fixed on the profile back. The anchor channel is embedded surface-flush in the concrete. GL Locatelli channel bolt (hook-head) with the appropriate hexagon nuts and washers will be inserted in the channel. HGP smart anchor channel is composed of GP channel with HGP channel nuts pre-installed into the channel and HGP threaded rod.

The product description is given in Annex A.

2. SPECIFICATION OF THE INTENDED USE IN ACCORDANCE WITH EUROPEAN ASSESSMENT DOCUMENT N° 330008-03-0601 (hereinafter EAD)

The anchor channels are intended to be used for anchorage under predominately static or quasi-static loading and fatigue cyclic load in reinforced or unreinforced normal weight concrete of strength classes C12/15 to C90/105 according to EN 206-1:2000.

Concerning product packaging, transport and storage it is the responsibility of the manufacturer to undertake the appropriate measures and to advise his clients on the transport and storage, as he considers necessary in order to reach the declared performances.

The information about installation is provided with the technical documentation from the Manufacturer and it is assumed that the product will be installed according to it or (in absence of such instructions) according to the usual practice of the building professionals.

The specifications and conditions given by the manufacturer are summarized in Annex B.

The performances assessed in this European Technical Assessment, according to the applicable EAD, are based on an assumed intended working life of at least 50 years, provided that the conditions for packaging, transport, storage, installation as well as appropriate use, maintenance and repair are met. The indications given on the working life cannot be interpreted as a guarantee given by the manufacturer, but are to be regarded only as a means for choosing the right products in relation to the expected economically reasonable working life of the works.

3. PERFORMANCE OF THE PRODUCT AND REFERENCES TO THE METHODS USED FOR ITS ASSESSMENT

The tests for performance assessment of the anchor channels were carried out in compliance with EAD 330008-03-0601 according to the test methods reported herein, as well for what concerns sampling, conditioning and testing provisions.

The numbering (#) in the following tables corresponds to the numbering of Table 2.1 of EAD 330008-03-0601.

3.1 MECHANICAL RESISTANCE AND STABILITY (BWR 1)

#	Essential characteristic	Performance
Characteristic resistance under static and quasi-static tension loading		
1	Resistance to steel failure of anchor	See Annex C1/1; Table C1
2	Resistance to steel failure of the connection between anchors and channel	See Annex C1/1; Table C1
3	Resistance to steel failure of channel lips and subsequently pull-out of channel bolt	See Annex C1/1; Table C1
4	Resistance to steel failure of channel bolt	See Annex C1/2; Table C2
5	Resistance to steel failure by exceeding the bending strength of the channel	See Annex C1/3; Table C3
6	Maximum installation torque moment to avoid damage during installation	See Annex B3; Table B3
7	Resistance to pull-out failure of the anchor	See Annex C1/3; Table C4
8	Resistance to concrete cone failure	See Annex C1/3; Table C4
9	Minimum edge distances, spacing and member thickness to avoid concrete splitting during installation	See Annex B2; Table B1
10	Characteristic edge distances and spacing to avoid splitting of concrete under load	See Annex C1/3; Table C4
11	Resistance to blowout failure – bearing area of anchor head	See Annex A5; Table A6
Characteristic resistance under static and quasi-static shear loading		
12	Resistance to steel failure of channel bolt under shear loading without lever arm	See Annex C2/1; Table C5
13	Resistance to steel failure by bending of the channel bolt under shear load with lever arm	See Annex C2/1; Table C5
14	Resistance to steel failure of channel lips, steel failure of connection between anchor and channel or steel failure of anchor (shear load in transverse direction)	See Annex C2/2; Table C6
15	Resistance to steel failure of connection between channel lips and channel bolt (shear load in longitudinal channel axis)	See Annex C2/3; Table C7
16	Factor for sensitivity to installation	See Annex C2/3; Table C7
17	Resistance to steel failure of the anchor	See Annex C2/3; Table C7
18	Resistance to steel failure of connection between anchor and channel	See Annex C2/3; Table C7
19	Resistance to concrete pry-out failure	See Annex C2/4; Table C8
20	Resistance to concrete edge failure	See Annex C2/4; Table C8

Characteristic resistance under combined static and quasi-static tension and shear loading		
21	Resistance to steel failure of the anchor channel	See Annex C2/4; Table C9
Characteristic resistance under fatigue tension loading		
22	Fatigue resistance to steel failure of the whole system (continuous or tri-linear function)	See Annex C3/1; Table C10
23	Fatigue limit resistance to steel failure of the whole system	See Annex C3/1; Table C11
24	Fatigue resistance to concrete related failure (exponential function)	See Annex C3/2; Table C12 and Table C13
25	Fatigue limit resistance to concrete related failure	See Annex C3/2; Table C14
26	Displacements	See Annex C4; Table C15 and Table C16

3.2 SAFETY IN CASE OF FIRE (BWR 2)

#	Essential characteristic	Performance
27	Reaction to fire	Class A1
28	Resistance to fire	See Annex C5

3.3 ASPECTS OF DURABILITY LINKED WITH THE BASIC WORKS REQUIREMENTS

#	Essential characteristic	Performance
29	Durability	No Performance Assessed

4. ASSESSMENT AND VERIFICATION OF CONSTANCY OF PERFORMANCE (AVCP) SYSTEM APPLIED, WITH REFERENCE TO ITS LEGAL BASE

In accordance with the European Assessment Document EAD No. 330008-03-0601 the applicable European legal act is: **Decision 2000/273/EC**.

The system of assessment and verification of constancy of performance (AVCP) is 1.

5. TECHNICAL DETAILS NECESSARY FOR THE IMPLEMENTATION OF THE AVCP SYSTEM, AS PROVIDED FOR IN EAD 330008-03-0601

Technical details necessary for the implementation of the AVCP system are laid down in the Control Plan deposited at ITC-CNR.

**Issued in San Giuliano Milanese, Italy on 19/04/2023
by ITC – CNR**

**Eng. Antonio Bonati
Acting Director of ITC-CNR**

GP Anchor Channel

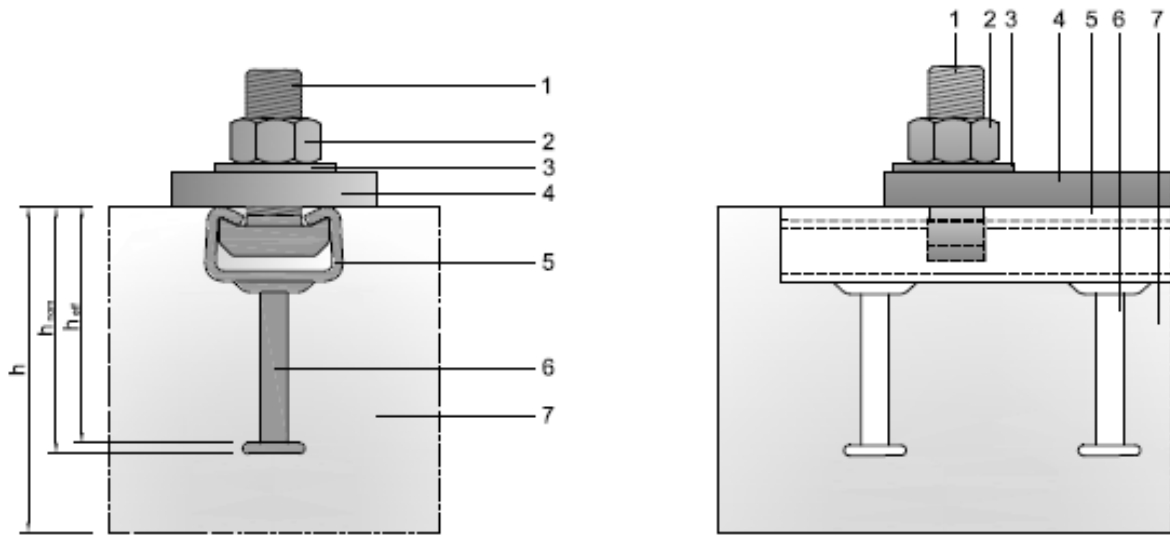

- 1 Channel Bolt
- 2 Hexagonal Nut
- 3 Washer
- 4 Fixture
- 5 Channel profile
- 6 Anchor
- 7 Concrete Member
- 8 HGP Threaded rod
- 9 HGP Channel Nut (pre-installed)

HGP Smart Anchor Channel

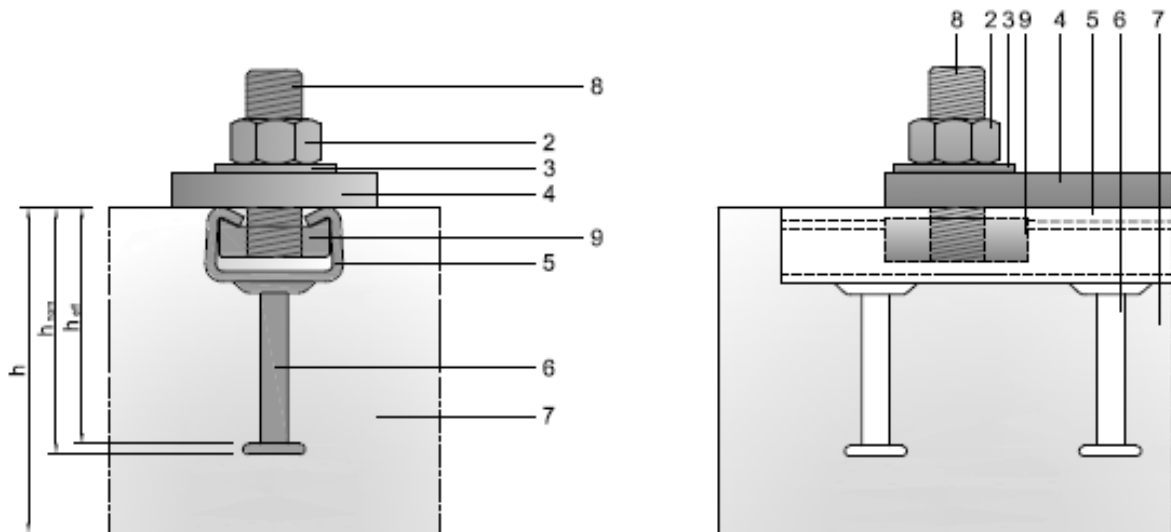

**GL LOCATELLI anchor channels (GP) with channel bolts (V)
and smart anchor channels (HGP)**

Product Description – Installed Condition

**Annex A1
of ETA N° 17/0869**

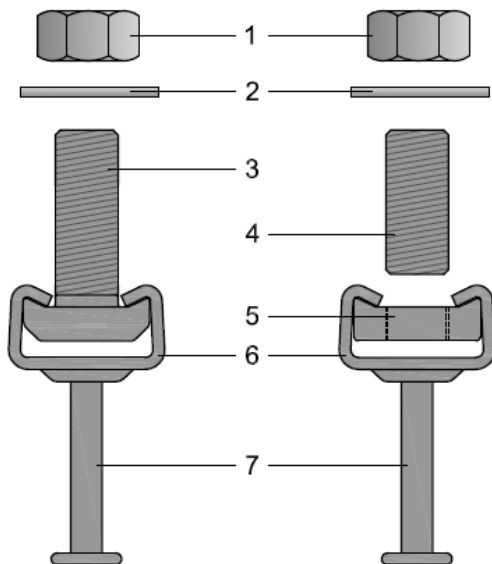

- 1 Hexagonal Nut
- 2 Washer
- 3 Channel Bolt
- 4 HGP Threaded rod
- 5 HGP Channel Nut (pre-installed)
- 6 Channel Profile
- 7 Anchor

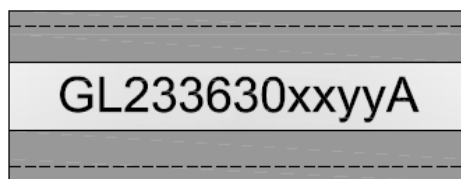

Marking of the GL Locatelli anchor channel

GL = GL LOCATELLI
 23 = Size of anchor channel
 36 = Material
 30 = Thickness
 xx = Week of production
 yy = Year of production
 A = Production site



Marking of the GL Locatelli channel bolt

GL = GL LOCATELLI
 V = Production site
 1 = Job lot code
 88 = Steel grade

GL LOCATELLI anchor channels (GP) with channel bolts (V) and smart anchor channels (HGP)

Product Description – Product and Marking

**Annex A2
 of ETA N° 17/0869**

Table A1: Materials for channel profiles

	GP40/223 – HGP40/223			GP50/30 – HGP50/30			GP54/33 – HGP54/33	
Channel profile	Steel S235JR (1.0038) [EN 10025] electroplated 19 to 21 µm $f_{yk} = 235 \text{ N/mm}^2$ $f_{uk} = 360 \text{ N/mm}^2$	Steel S235JR (1.0038) [EN 10025] hot-dip galvanized ≥ 55 µm $f_{yk} = 235 \text{ N/mm}^2$ $f_{uk} = 360 \text{ N/mm}^2$	Steel S235JR (1.0038) [EN 10025] hot-dip galvanized with sendzimir 16 to 20 µm $f_{yk} = 235 \text{ N/mm}^2$ $f_{uk} = 360 \text{ N/mm}^2$	Steel S420MC (1.0980) [EN 10149-2] electroplated 19 to 21 µm $f_{yk} = 420 \text{ N/mm}^2$ $f_{uk} = 480 \text{ N/mm}^2$	Steel S420MC (1.0980) [EN 10149-2] hot-dip galvanized ≥ 55 µm $f_{yk} = 420 \text{ N/mm}^2$ $f_{uk} = 480 \text{ N/mm}^2$	Steel S420MC (1.0980) [EN 10149-2] hot-dip galvanized with sendzimir 16 to 20 µm $f_{yk} = 420 \text{ N/mm}^2$ $f_{uk} = 480 \text{ N/mm}^2$	Steel S235JR (1.0038) [EN 10025] hot-dip galvanized ≥ 55 µm $f_{yk} = 235 \text{ N/mm}^2$ $f_{uk} = 360 \text{ N/mm}^2$	Steel S235JR (1.0038) [EN 10025] electroplated 19 to 21 µm $f_{yk} = 235 \text{ N/mm}^2$ $f_{uk} = 360 \text{ N/mm}^2$
	Stainless steel A2 (AISI 304/304L) [EN 10088] $f_{yk} = 230 \text{ N/mm}^2$ $f_{uk} = 540 \text{ N/mm}^2$ Stainless steel A4 (AISI 316/316L) [EN 10088] $f_{yk} = 240 \text{ N/mm}^2$ $f_{uk} = 540 \text{ N/mm}^2$ Stainless steel AISI 430 [EN 10088] $f_{yk} = 250 \text{ N/mm}^2$ $f_{uk} = 430 \text{ N/mm}^2$						Stainless steel A4 (AISI 316/316L) [EN 10088] $f_{yk} = 240 \text{ N/mm}^2$ $f_{uk} = 540 \text{ N/mm}^2$	

**GL LOCATELLI anchor channels (GP) with channel bolts (V)
and smart anchor channels (HGP)**

Product Description – Material

**Annex A3/1
of ETA N° 17/0869**

Table A2: Materials for anchors

Channel	GP40/223 – HGP40/223			GP50/30 – HGP50/30			GP54/33 – HGP54/33	
Anchor	Steel CB10FF (1.0214) [EN 10263] electroplated ≥ 9 μm $f_{yk} = 420 \text{ N/mm}^2$ $f_{uk} = 480 \text{ N/mm}^2$	Steel CB10FF (1.0214) [EN 10263] hot-dip galvanized ≥ 55 μm $f_{yk} = 420 \text{ N/mm}^2$ $f_{uk} = 480 \text{ N/mm}^2$	Steel CB10FF (1.0214) [EN 10263] electroplated ≥ 9 μm $f_{yk} = 420 \text{ N/mm}^2$ $f_{uk} = 480 \text{ N/mm}^2$	Steel CB10FF (1.0214) [EN 10263] electroplated ≥ 9 μm $f_{yk} = 420 \text{ N/mm}^2$ $f_{uk} = 480 \text{ N/mm}^2$	Steel CB10FF (1.0214) [EN 10263] hot-dip galvan. ≥ 55 μm $f_{yk} = 420 \text{ N/mm}^2$ $f_{uk} = 480 \text{ N/mm}^2$	Steel CB10FF (1.0214) [EN 10263] electroplated ≥ 9 μm $f_{yk} = 420 \text{ N/mm}^2$ $f_{uk} = 480 \text{ N/mm}^2$	Steel St 52-3 (1.0570) [EN 10027-2] hot-dip galvanized ≥ 55 μm $f_{yk} = 355 \text{ N/mm}^2$ $f_{uk} = 520 \text{ N/mm}^2$	Steel St 52-3 (1.0570) [EN 10027-2] electroplated ≥ 9 μm $f_{yk} = 355 \text{ N/mm}^2$ $f_{uk} = 520 \text{ N/mm}^2$
	Stainless steel A2 (AISI 304/304L) [EN 10088] $f_{yk} = 230 \text{ N/mm}^2$ $f_{uk} = 540 \text{ N/mm}^2$ Stainless steel A4 (AISI 316/316L) [EN 10088] $f_{yk} = 240 \text{ N/mm}^2$ $f_{uk} = 540 \text{ N/mm}^2$						Stainless steel A4 (AISI 316/316L) [EN 10088] $f_{yk} = 240 \text{ N/mm}^2$ $f_{uk} = 540 \text{ N/mm}^2$	

GL LOCATELLI anchor channels (GP) with channel bolts (V) and smart anchor channels (HGP)

Product Description – Material

**Annex A3/2
of ETA N° 17/0869**

Table A3: Materials for channel bolts and smart channel bolt

Channel	GP40/223 - GP50/30 - GP54/33		HGP40/223 - HGP50/30		HGP54/33	
Channel Bolt (V40/22 – V50/300) (acc. to EN ISO 4018)	Carbon steel Steel grade 4.6/8.8 [EN ISO 898-1]	Carbon steel Steel grade 4.6/8.8 [EN ISO 898-1]				
	electroplated ≥ 12 µm	hot-dip galvan. ≥ 40 µm				
Stainless Steel Steel grade 50/70 [EN ISO 3506-1]						
HGP Channel Nut (ADHZ40 – ADHZ50 – ADHZ54)			Carbon Steel S275JR [EN 10025]	Carbon Steel S275JR [EN 10025]	Carbon Steel S275JR [EN 10025]	Carbon Steel S275JR [EN 10025]
			electroplated 19 to 21 µm	hot-dip galvanized. ≥ 55 µm	electroplated 19 to 21 µm	hot-dip galvanized. ≥ 55 µm
			Stainless steel A2 (AISI 304/304L) [EN 10088] $f_{yk} = 230 \text{ N/mm}^2$ $f_{uk} = 540 \text{ N/mm}^2$		Stainless steel A4 (AISI 316/316L) [EN 10088] $f_{yk} = 240 \text{ N/mm}^2$ $f_{uk} = 540 \text{ N/mm}^2$	
			Stainless steel AISI 430 [EN 10088] $f_{yk} = 250 \text{ N/mm}^2$ $f_{uk} = 430 \text{ N/mm}^2$		Stainless steel A4 (AISI 316/316L) [EN 10088] $f_{yk} = 240 \text{ N/mm}^2$ $f_{uk} = 540 \text{ N/mm}^2$	
H-bolt (threaded rod)			Carbon Steel Steel grade 4.6/8.8 [EN ISO 898-1]	Carbon Steel Steel grade 4.6/8.8 [EN ISO 898-1]	Carbon Steel Steel grade 4.6/8.8 [EN ISO 898-1]	Carbon Steel Steel grade 4.6/8.8 [EN ISO 898-1]
			electroplated ≥ 12 µm	hot-dip galvan. ≥ 40 µm	electroplated ≥ 12 µm	hot-dip galvan. ≥ 40 µm
			Stainless Steel Steel grade 70 [EN ISO 3506-1]			
Washer (acc. to EN ISO 7089 and EN ISO 7093-1, production class A, 200 HV)	Carbon Steel [EN 10025]	Carbon Steel [EN 10025]	Carbon Steel [EN 10025]	Carbon Steel [EN 10025]	Carbon Steel [EN 10025]	Carbon Steel [EN 10025]
	electroplated ≥ 5 µm	hot-dip galvan. ≥ 40 µm	electroplated ≥ 5 µm	hot-dip galvan. ≥ 40 µm	electroplated ≥ 5 µm	hot-dip galvan. ≥ 40 µm
		Stainless steel A2 (AISI 304/304L) [EN 10088] $f_{yk} = 230 \text{ N/mm}^2$ $f_{uk} = 540 \text{ N/mm}^2$	Stainless steel A2 (AISI 304/304L) [EN 10088] $f_{yk} = 230 \text{ N/mm}^2$ $f_{uk} = 540 \text{ N/mm}^2$		Stainless steel A4 (AISI 316/316L) [EN 10088] $f_{yk} = 240 \text{ N/mm}^2$ $f_{uk} = 540 \text{ N/mm}^2$	
		Stainless steel A4 (AISI 316/316L) [EN 10088] $f_{yk} = 240 \text{ N/mm}^2$ $f_{uk} = 540 \text{ N/mm}^2$	Stainless steel A4 (AISI 316/316L) [EN 10088] $f_{yk} = 240 \text{ N/mm}^2$ $f_{uk} = 540 \text{ N/mm}^2$			
Hexagonal nut (acc. to EN ISO 4032)	Carbon Steel Strength grade 5/8 [EN 20898-2]	Carbon Steel Strength grade 5/8 [EN 20898-2]	Carbon Steel Strength grade 5/8 [EN 20898-2]	Carbon Steel Strength grade 5/8 [EN 20898-2]	Carbon Steel Strength grade 5/8 [EN 20898-2]	Carbon Steel Strength grade 5/8 [EN 20898-2]
	electroplated ≥ 5 µm	hot-dip galvan. ≥ 40 µm	electroplated ≥ 5 µm	hot-dip galvan. ≥ 40 µm	electroplated ≥ 5 µm	hot-dip galvan. ≥ 40 µm
Stainless Steel Steel grade 70/80 [EN ISO 3506-1]			Stainless Steel Steel grade 70/80 [EN ISO 3506-1]			

GL LOCATELLI anchor channels (GP) with channel bolts (V) and smart anchor channels (HGP)	Annex A3/3 of ETA N° 17/0869
Product Description – Material	

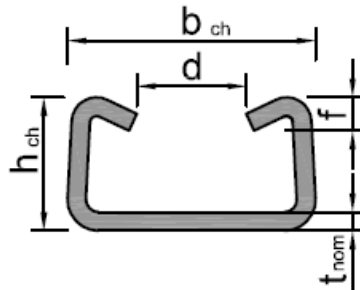

Marking of the channel according to Annex A2

Table A4: Geometry

Anchor channel	b_{ch}	h_{ch}	t_{nom}	d	f	I_y
	[mm]					[mm ³]
GP40/223 HGP40/223	40,8	22	3	18	5,50	14616
GP50/30 HGP50/30	50	28,5	3	22	6,50	40198
GP54/33 HGP54/33	55	34	5	22	8,80	83800

**GL LOCATELLI anchor channels (GP) with channel bolts (V)
and smart anchor channels (HGP)**

Product Description – Profile Dimensions

**Annex A4
of ETA N° 17/0869**

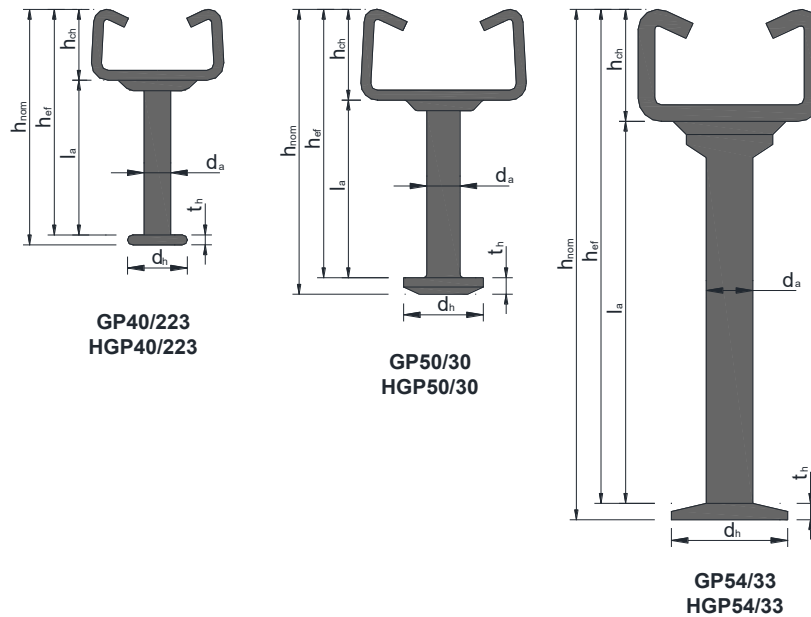

Table A5: Anchor dimensions

Anchor channel	h_{nom}	h_{ef}
	[mm]	
GP40/223 HGP40/223	72	69,0
GP50/30 HGP50/30	87	81,5
GP54/33 HGP54/33	154	150,0

Table A6: Round anchor dimensions

Round anchor	d_a	d_h	min l_a	t_h	A_h
	[mm]				[mm ²]
GP40/223 HGP40/223	8	18	47	3,0	204,2
GP50/30 HGP50/30	10	24	53	5,5	373,8
GP54/33 HGP54/33	14	35	116	4,0	808,2

GL LOCATELLI anchor channels (GP) with channel bolts (V) and smart anchor channels (HGP)

Product Description – Anchor Dimensions

**Annex A5
of ETA N° 17/0869**

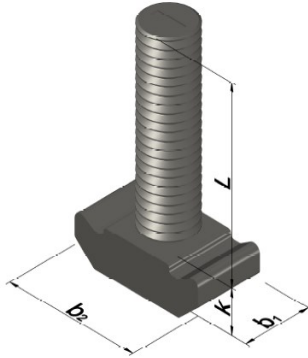

Table A7: Dimensions for channel bolt

Anchor channel	Channel bolt	b ₁	b ₂	k	Ø
					[mm]
GP40/223	V40/22	16,5	32,1	11	10
					12
					14
					16
GP50/30	V50/300	20,5	41,5	15	10
					12
					14
					16
					20
GP54/33	V50/300	20,5	41,5	15	10
					12
					14
					16
					20

Table A8: Channel bolt steel strength grade

Grade	Carbon Steel		Stainless Steel	
	4.6	8.8	50	70
f _{uk} [MPa]	400	800	500	700
f _{yk} [MPa]	240	640	210	450
Finishing coat	Zinc plated - HDG		-	

GL LOCATELLI anchor channels (GP) with channel bolts (V) and smart anchor channels (HGP)

Product Description – Channel Bolt Dimensions and Steel Grade

Annex A6
of ETA N° 17/0869

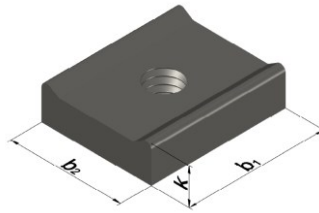

Table A9: Dimensions for HGP Channel Nut

Anchor channel	Channel Nut	b ₁	b ₂	k	Ø
		[mm]			
HGP40/223	ADHZ40	50	32,1	13,0	12-14-16
HGP50/30	ADHZ50	50	40,5	13,9	16
HGP54/33	ADHZ54	50	42,5	19,9	16

Table A10: HGP Channel Nut strength grade

Grade	Carbon Steel	Stainless Steel		
	S275JR	A2	A4	AISI430
f _{uk} [MPa]	410	540	540	430
f _{yk} [MPa]	275	230	240	250
Finishing coat	Electroplated - HDG	-		

Table A11: HGP Threaded Rod steel strength grade

Grade	Carbon Steel		Stainless Steel
	4.6	8.8	70
f _{uk} [MPa]	400	800	700
f _{yk} [MPa]	240	640	450
Finishing coat	Zinc plated - HDG		-

GL LOCATELLI anchor channels (GP) with channel bolts (V) and smart anchor channels (HGP)

Product Description – Channel Nuts Dimensions and Steel Grade

Annex A7
of ETA N° 17/0869

SPECIFICATION OF INTENDED USE

Anchor channels and channel bolts/ smart channel bolts subject to:

- Static and quasi-static loads in tension and shear longitudinal and perpendicular to the longitudinal axis of the channel;
- Fatigue loading;
- Fire exposure only for concrete class C20/25 to C50/60.

Base materials:

- Reinforced or unreinforced normal weight concrete according to EN 206-1:2000.
- Strength classes C12/15 to C90/105 according to EN 206-1:2000.
- Cracked or non-cracked concrete.

Use conditions (Environmental conditions):

- Structures subject to dry internal conditions (e.g. accommodations, bureaus, schools, hospitals, shops, exceptional internal conditions with usual humidity):
anchor channels and channel bolts according to Annex A3-A4.
- Structures subject to internal conditions with usual humidity (e.g. kitchen, bath and laundry in residential buildings, exceptional permanent damp conditions and application under water):
anchor channels and channel bolts according to Annex A3-A4.

Design:

- Anchor channels are designed under the responsibility of an engineer experienced in anchorages and concrete work
- Verifiable calculation notes and drawings are prepared taking account of the loads to be anchored. The position of the anchor channel and channel bolts are indicated on the design drawings (e.g. position of the anchor channel relative to the reinforcement or to supports).
- For static and quasi-static loading the anchor channels are designed in accordance with EOTA TR 047 "Calculation Method for the Performance of Anchor Channels" and according to EN 1992-4.
- For fatigue loading the anchor channel is designed in accordance with EOTA TR 050 "Calculation Method for the Performance of Anchor Channels" and according to EN 1992-4.
- The characteristic resistances are calculated with the minimum effective embedment depth.

INSTALLATION INSTRUCTIONS

- Anchor channel installation is carried out by appropriately qualified personnel and under the supervision of the person responsible for technical matters on site.
- Use of the anchor channel only as supplied by the manufacturer – without any manipulations, repositioning or exchanging of channel components.
- Cutting of anchor channels is allowed only if pieces according to Annex B2, Table B1 are generated including end spacing and minimum channel length and only to be use in dry internal conditions.
- Anchor channel installation in accordance with the manufacturer's specifications and the design drawings.
- The anchor channels are fixed on the framework, reinforcement or auxiliary construction such that no movement of the channels will occur during the time of laying the reinforcement and of placing and compacting the concrete.
- The concrete under the head of the anchors are properly compacted. The channels are protected from penetration of concrete into the internal space of the channels.
- Washer may be chosen according to Annex A5 and provided separately by the user.
- Size and spacing of channel bolts corresponding to the design drawings.
- Orientate the channel bolt rectangular to the channel axis.
- The required installation torques given in Annex B3 must be applied and must not be exceeded.

GL LOCATELLI anchor channels (GP) with channel bolts (V) and smart anchor channels (HGP)

Intended Use – Specifications and Installation Instructions

Annex B1
of ETA N° 17/0869

Table B1: Installation parameters for anchor channels

Anchor channel		GP40/223 HGP40/223	GP50/30 HGP50/30	GP54/33 HGP54/33
Minimum spacing	s_{min}	95	90	120
Maximum spacing	s_{max}	250		
End spacing	X	27,5	30	40
Minimum channel length	l_{min}	150		200
Minimum edge distance	c_{min}	50	75	100
Minimum thickness of concrete member	h_{min}	102	117	183
Minimum effective embedment depth	$h_{ef,min}$	69	81,5	150

Table B2: Minimum spacing for channel bolt

Channel bolt		M8	M10	M12	M14	M16	M20
Minimum spacing between channel bolts	$s_{cbo,min}$ [mm]	40	50	60	70	80	100

$s_{cbo,min}$ = center to center spacing between channel bolts ($s_{cbo,min}=5d$)

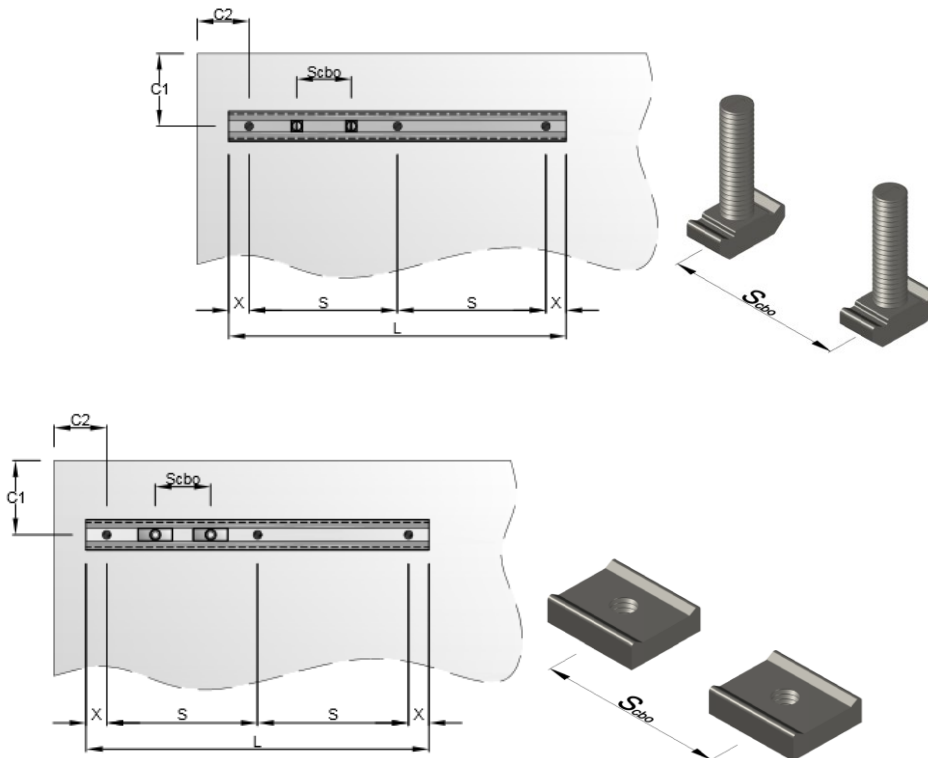

GL LOCATELLI anchor channels (GP) with channel bolts (V) and smart anchor channels (HGP)

Intended Use – Installation parameters for anchor channel and channel bolts

Annex B2
of ETA N° 17/0869

Table B3: Required installation torque T_{inst}

Channel Bolt		T_{inst} [Nm]					
		General			Steel to steel contact		
		GP40/223 HGP40/223	GP50/30 HGP50/30	GP54/33 HGP54/33	GP40/223 HGP40/223	GP50/30 HGP50/30	GP54/33 HGP54/33
M10	4.6, 8.8	15	15	15	15	15	15
	50,70	- ⁽¹⁾	- ⁽¹⁾	- ⁽¹⁾	- ⁽¹⁾	- ⁽¹⁾	- ⁽¹⁾
M12	4.6, 8.8	25	25	25	25	25	25
	50,70	25	25	25	25	25	25
M14	4.6, 8.8	35	35	35	35	35	35
	50,70	- ⁽¹⁾	- ⁽¹⁾	- ⁽¹⁾	- ⁽¹⁾	- ⁽¹⁾	- ⁽¹⁾
M16	4.6, 8.8	35	60	60	45	60	60
	50,70	45	60	60	45	60	60
M20	4.6, 8.8	- ⁽¹⁾	60	100	- ⁽¹⁾	75	120
	50, 70	- ⁽¹⁾	60	100	- ⁽¹⁾	75	120

⁽¹⁾ product not available

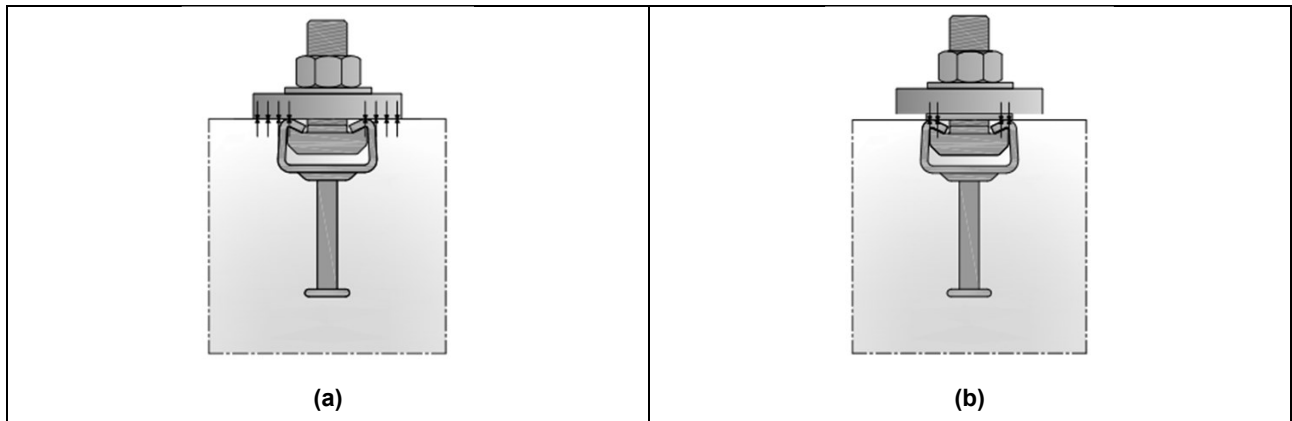

- a) General:** The fixture is in contact with the channel profile and the concrete surface
- b) Steel-steel contact:** The fixture is fastened to the anchor channel by suitable steel part (e.g. washer).
Fixture is in contact with the channel profile only.

**GL LOCATELLI anchor channels (GP) with channel bolts (V)
and smart anchor channels (HGP)**

Intended Use – Installation parameters for channel bolts

**Annex B3
of ETA N° 17/0869**

Installazione in cantiere

Installazione nel cassero dei profili di ancoraggio GP e HGP

Installation in the building yard

Installation in the formwork of GP and HGP anchor channels

Posizionare il profilo di ancoraggio nel cassero rispettando le distanze minime C1 e C2

Respecting the minimum distances C1 and C2

Distanza minima dai bordi- mm - Minimum edge distance									
Profilo Channel	HGP54/33	HGP50/30	HGP40/223	GP40/221	GP38/17	GPK2	GP1	GL1	
C1,C2	100	75	50	50	50	50	50	50	

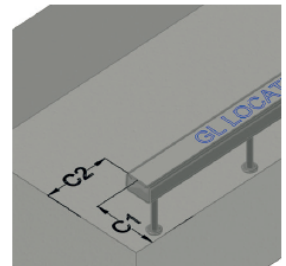

Fissare il profilo affinché rimanga in posizione durante il getto, a scelta: legare alle armature, incollare con silicone, inchiodare al cassero di legno

Fixing the profile in order to have it in position during the concrete pouring, choosing between: binding it to the reinforcement, glue it with silicone or nail it the wooden formwork

Eseguire il getto in calcestruzzo e compattare vibrando.

Make the concrete casting and vibrate it in order to compact the mix.

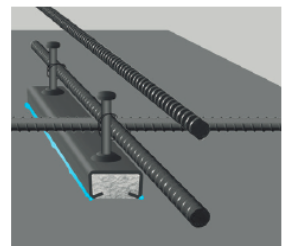
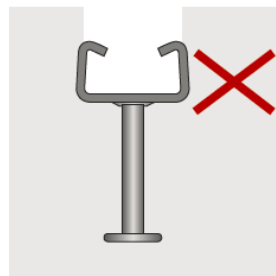
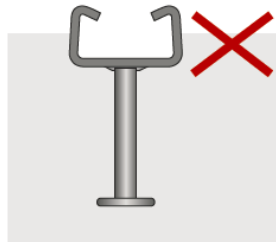
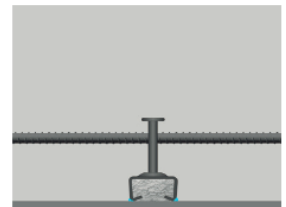

GL LOCATELLI anchor channels (GP) with channel bolts (V) and smart anchor channels (HGP)

Intended Use – Installation instructions for anchor channels

Annex B4
of ETA N° 17/0869

Installazione dell'ancoraggio

Rimuovere il riempimento di schiuma dal profilo

HGP - avvitare il grano M16x60 nel connettore all'interno del profilo. Il grano è completamente avvitato quando il filetto BLU non è più visibile.
Eseguire l'ancoraggio con dadi e rondelle piane rispettando la coppia di chiusura M16.

GP - inserire la vite testa ad ancora nel profilo e ruotare la vite di 90° in senso orario in modo che la testa si ancori alle estremità del profilo.

Verificare il corretto posizionamento della vite ad ancora.
La scanalatura presente sotto al gambo della vite deve essere perpendicolare all'asse longitudinale del profilo.
Installare le viti a una distanza superiore a 40 mm dall'estremità laterale del profilo GP.
Eseguire l'ancoraggio con dadi e rondelle piane rispettando la coppia di chiusura.

Anchorage installation

Remove the foam filling from the channel

HGP - screw the M16x60 socket into the link inside the profile.
The sockets are completely screwed when the BLUE thread will disappear.
Carry out the fixing with nut and flat washers respecting the M16 torque hammer-head.

GP - insert the channel bolt into the channel slot and rotate the channel bolt of 90° clockwise in a way that the head anchor itself to the edges of the profile.

Check the correct positioning of the GL Locatelli hammer-head channel bolt.
The groove on the shank end of the channel bolt must be perpendicular to the channel longitudinal axis.
Install the channel bolts at a distance higher than 40 mm from the lateral edge of the GP anchor channel.
Carry out the fixing with nuts and flat washers respecting the torque.

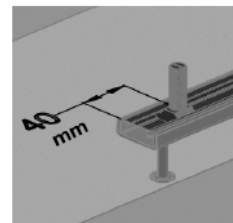
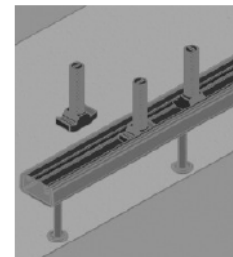
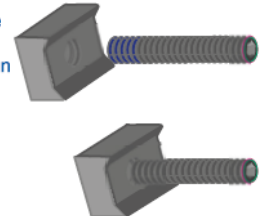
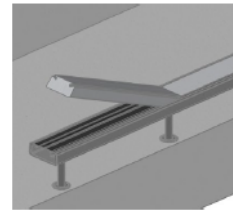

GL LOCATELLI anchor channels (GP) with channel bolts (V) and smart anchor channels (HGP)

Intended Use – Installation instructions for V bolts and HGP bolts

Annex B5/1
of ETA N° 17/0869

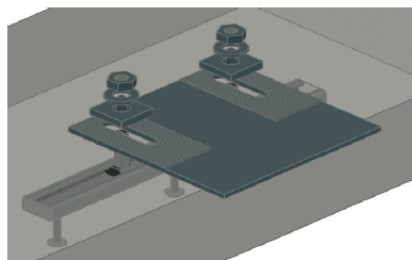
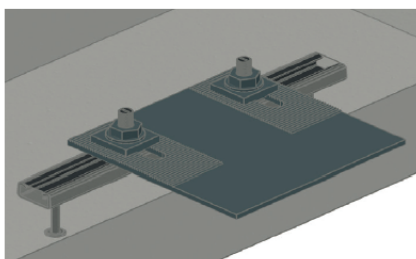

Coppia di serraggio (cls-acciaio) - Tinst Nm - Recommended torque (concrete-steel)

Profilo Channel	HGP54/33	GP54/33	HGP50/30	GP50/30	HGP40/223	GP40/223	GP40/221	GP38/17	GPK2	GP1	GL1
Vite Screw	HGP	V50/300	HGP	V50/30	HGP	V40/22	V40/22	V38/17	VM4	VM3	VM3
M 8	-	-	-	-	-	-	-	-	15	-	-
M 10	-	15	-	15	-	15	15	15	15	15	15
M 12	-	25	-	25	-	25	25	25	25	25	25
M 14	-	35	-	35	-	35	35	35	-	-	-
M 16	60	60	60	60	60	35	35	35	-	-	-
M 20	-	100	-	60	-	-	-	-	-	-	-

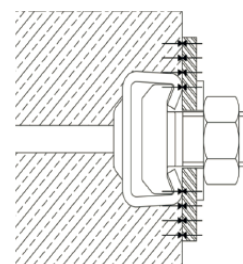

Coppia di serraggio (acciaio-acciaio) - Tinst Nm - Recommended torque (steel-steel)

Profilo Channel	HGP54/33	GP54/33	HGP50/30	GP50/30	HGP40/223	GP40/223	GP40/221	GP38/17	GPK2	GP1	GL1
Vite Screw	HGP	V50/300	HGP	V50/30	HGP	V40/22	V40/22	V38/17	VM4	VM3	VM3
M 8	-	-	-	-	-	-	-	-	15	-	-
M 10	-	15	-	15	-	15	15	15	15	15	15
M 12	-	25	-	25	-	25	25	25	25	25	25
M 14	-	35	-	35	-	35	35	35	-	-	-
M 16	60	60	60	60	60	45	45	45	-	-	-
M 20	-	120	-	75	-	-	-	-	-	-	-

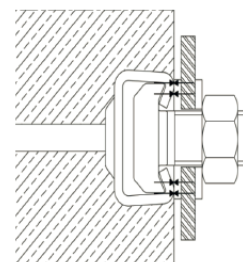

Profili di ancoraggio - Anchor channel

	Tipo	Acciaio	Norma UNI	Zincatura Sendzimir	Zincatura a caldo
	Type	Steel	Norm	Sendzimir galvanized	Hot dip galvanized
Profilo	GP54/33	1.0038	EN 10025		≥ 55 µm
Chiodo		1.0570	EN 10027-2		≥ 55 µm
Profilo	GP50/30	1.0980	EN 10149-2		≥ 55 µm
Chiodo		1.0214	EN 10263		≥ 55 µm
Profilo	GP40/223 GP40/221	1.0038	EN 10025	da 19 a 21 µm	≥ 55 µm
Chiodo		1.0214	EN 10263	da 19 a 21 µm	≥ 55 µm
Profilo	GP1 GL1	1.0038	EN 10025	da 19 a 21 µm	≥ 55 µm

Accessori - Accessories

	Acciaio	Norma UNI	Zincatura Elettrolitica	Zincatura a caldo
	Steel	Norm	Electrolitic galvanized	Hot dip galvanized
Viti spec GL e barra fil. EN ISO 4018	grado 4.6 e 8.8	EN ISO 898-1	≥ 12 µm	≥ 40 µm
Rondelle EN ISO 7089 e EN ISO 7093-1 classe a 200HV	acciaio	EN 10025	≥ 5 µm	≥ 40 µm
Viti T. Esagonale EN ISO 4042		EN 20898-2	≥ 5 µm	≥ 40 µm

GL LOCATELLI anchor channels (GP) with channel bolts (V) and smart anchor channels (HGP)

Intended Use – Installation instructions for V bolts and HGP bolts

Annex B5/2
of ETA N° 17/0869

Table C1: Characteristic resistance under static and quasi-static tension loading – steel failure

Anchor channel		Steel	GP40/223 HGP40/223	GP50/30 HGP50/30	GP54/33	HGP54/33	
Steel failure - Anchor							
Characteristic resistance	$N_{Rk,s,a}$	[kN]	carbon	24,1	37,7	80	80
			stainless	27,2	42,4	83,1	83,1
Partial safety factor	$\gamma_{Ms}^{1)}$	[-]	1,4	1,4	1,8	1,8	
Steel failure - Connection channel/anchor							
Characteristic resistance	$N_{Rk,s,c}$	[kN]	carbon	20,4	31,1	57,7	76,8
			stainless	20,4	31,1	57,7	76,8
Partial safety factor	$\gamma_{Ms,ca}^{1)}$	[-]	1,8				
Steel failure - Channel lips							
Axial spacing	$s_{l,N}$	[mm]	81,6	100	110	110	
Characteristic resistance	$N_{Rk,s,l}^0$	[kN]	carbon	20,4	31,1	57,7	76,8
			stainless	20,4	31,1	57,7	76,8
Partial safety factor	$\gamma_{Ms,l}^{1)}$	[-]	1,8				

GL LOCATELLI anchor channels (GP) with channel bolts (V) and smart anchor channels (HGP)

Performances – Characteristic resistance under static and quasi-static tension loading

**Annex C1/1
of ETA N° 17/0869**

Table C2: Characteristic resistance under static and quasi-static tension loading – steel failure – channel bolts

Channel bolt				M10	M12	M14	M16	M20			
Steel failure											
Characteristic resistance	N _{Rk,s}	[kN]	V40/22	4,6	23,2	33,7	46,0	62,8	- ¹⁾		
				8,8	46,4	67,4	92,0	125,6	- ¹⁾		
				50/70	23,2	33,7	46,0	62,8	- ¹⁾		
			V50/300	4,6	23,2	33,7	46,0	62,8	98,0		
				8,8	46,4	67,4	92,0	125,6	196,0		
				50,70	23,2	33,7	46,0	62,8	98,0		
			H-bolt+ ADHZ40	4,6	- ¹⁾	33,7	46,0	56,7	- ¹⁾		
				8,8	- ¹⁾	56,7	56,7	56,7	- ¹⁾		
				Stainless A2/A4 (f _{uk} =540 MPa)	- ¹⁾	33,7	46,0	56,7	- ¹⁾		
			H-bolt+ ADHZ50	4,6	- ¹⁾	- ¹⁾	- ¹⁾	56,7	- ¹⁾		
				8,8	- ¹⁾	- ¹⁾	- ¹⁾	56,7	- ¹⁾		
				Stainless A2/A4 (f _{uk} =540 MPa)	- ¹⁾	- ¹⁾	- ¹⁾	56,7	- ¹⁾		
			H-bolt+ ADHZ54	4,6	- ¹⁾	- ¹⁾	- ¹⁾	62,8	- ¹⁾		
				8,8	- ¹⁾	- ¹⁾	- ¹⁾	103,6	- ¹⁾		
				Stainless A2/A4 (f _{uk} =540 MPa)	- ¹⁾	- ¹⁾	- ¹⁾	62,8	- ¹⁾		
			Partial safety factor	γ _{Ms} ²⁾	[-]	4,6	2,0				
						8,8	1,5				
						50	2,86				
						70	1,87				
						Stainless A2	2,81				
						Stainless A4	2,7				

¹⁾ product not available

²⁾ In absence of other national regulations

GL LOCATELLI anchor channels (GP) with channel bolts (V) and smart anchor channels (HGP)

Performances – Characteristic resistance under static and quasi-static tension loading

**Annex C1/2
of ETA N° 17/0869**

Table C3: Characteristic resistance under static and quasi-static tension loading - Characteristic flexure resistance of channel

Anchor channel		Steel	GP40/223 HGP40/223	GP50/30 HGP50/30	GP54/33 HGP54/33	
Steel failure – Failure by flexure of channel						
Characteristic flexural resistance of channel	$M_{Rk,s,flex}$	[Nm]	carbon	1270	2299	3256
			stainless	1270	2299	3256
Partial safety factor	$\gamma_{Ms,flex}^{1)}$	[-]		1,15		

1) In absence of other national regulations

Table C4: Characteristic resistance under static and quasi-static tension loading – concrete failure

Anchor channel		GP40/223 HGP40/223	GP50/30 HGP50/30	GP54/33 HGP54/33	
Concrete pull-out failure					
Characteristic resistance in cracked concrete C12/15	$N_{Rk,p}$	[kN]	18,4	33,6	72,7
Characteristic resistance in uncracked concrete C12/15	$N_{Rk,p}$	[kN]	25,7	47,1	101,8
Amplification factor of $N_{Rk,p}$	C16/20	ψ_c	[-]	1,33	
	C20/25			1,67	
	C25/30			2,08	
	C30/37			2,50	
	C35/45			2,92	
	C40/50			3,33	
	C45/55			3,75	
	≥C50/60			4,17	
Partial safety factor	$\gamma_{Mp} = \gamma_{Mc}$		1,5		
Concrete cone failure $N_{Rk,c}$					
α_{ch}			0,866	0,888	0,973
Product factor k_1	Cracked concrete	$k_{cr,N}$	7,7	7,9	8,7
	Uncracked concrete	$k_{ucr,N}$	11,0	11,3	12,4
Partial safety factor	γ_{Mc}		1,5		
Concrete splitting failure					
Characteristic edge distance	$c_{cr,sp}$	[mm]	207	245	450
Characteristic spacing	$s_{cr,sp}$	[mm]	414	490	900
Partial safety factor	γ_{Msp}		1,5		

GL LOCATELLI anchor channels (GP) with channel bolts (V) and smart anchor channels (HGP)

Performances – Characteristic resistance under static and quasi-static tension loading

**Annex C1/3
of ETA N° 17/0869**

Table C5: Characteristic resistance under static and quasi static shear loading in transverse direction – steel failure – channel bolt

Channel bolt					M10	M12	M14	M16	M20	
Steel failure										
Characteristic resistance	$V_{Rk,s}$	[kN]	V40/22, V50/300	carbon	4.6	13,92	20,22	27,60	37,68	58,8
					8.8	23,20	33,70	46,00	62,70	97,90
				stainless steel	50	23,56	33,93	46,18	60,32	94,25
			70		32,99	47,50	64,65	84,45	131,95	
			H-bolt	carbon	4.6	- ¹⁾	20,22	27,60	37,68	- ¹⁾
					8.8	- ¹⁾	33,70	46,00	62,70	- ¹⁾
stainless steel	70	- ¹⁾	47,50	64,65	84,45	- ¹⁾				
	Characteristic flexure resistance	$M^0_{Rk,s^{(2)}}$	[Nm]	V40/22, V50/300	carbon	4.6	29,9	52,4	83,5	133,2
8.8						59,8	104,8	167,0	266,4	519,3
stainless steel					50	37,4	65,5	104,3	166,5	324,5
				70	52,3	91,7	146,1	233,1	454,4	
H-bolt				carbon	4.6	- ¹⁾	52,4	83,5	133,2	- ¹⁾
					8.8	- ¹⁾	104,8	167,0	266,4	- ¹⁾
stainless steel	70	- ¹⁾	91,7	146,1	233,1	- ¹⁾				
	Partial safety factor	$\gamma_{Ms^{(2)}}$	[-]	carbon	4.6	1,67				
8.8					1,25					
stainless steel				50	2,38					
				70	1,56					

¹⁾ product not available

²⁾ In absence of other national regulations

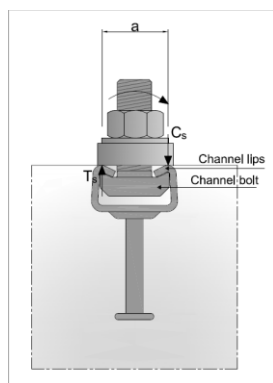

²⁾ The characteristic flexure resistance according to Table C5 shall be limited in design to:

$$M^0_{Rk,s} \leq 0,5 N^0_{Rk,s,l} \cdot a \quad (N^0_{Rk,s,l} \text{ according to Table C1})$$

$$M^0_{Rk,s} \leq 0,5 N_{Rk,s} \cdot a \quad (N_{Rk,s} \text{ according to Table C2})$$

with a reported in Table C6.

T_s tension force acting on the channel lips

C_s compression force acting on the channel lips

GL LOCATELLI anchor channels (GP) with channel bolts (V) and smart anchor channels (HGP)

Performances – Characteristic resistance under static and quasi-static shear loading

**Annex C2/1
of ETA N° 17/0869**

Table C6: Characteristic resistance under static and quasi static shear loading in transverse direction –steel failure anchor channel

Anchor channel			Steel	GP 40/223	HGP 40/223	GP 50/30	HGP 50/30	GP 54/33	HGP 54/33
Steel failure - Anchor									
Characteristic resistance	$V_{Rk,s,a,y}$	[kN]	carbon	20,4	41,3	31,1	71,6	57,7	76,8
			stainless	20,4	41,3	31,1	71,6	57,7	76,8
Partial safety factor	$\gamma_{Ms,a}^{1)}$	[-]	carbon/ stainless	1,14			1,46		
Steel failure - Connection channel/anchor									
Characteristic resistance	$V_{Rk,s,c,y}$	[kN]	carbon	20,4	41,3	31,1	71,6	57,7	76,8
			stainless	20,4	41,3	31,1	71,6	57,7	76,8
Partial safety factor	$\gamma_{Ms,ca}^{1)}$	[-]	carbon/ stainless	1,8					
Steel failure - Channel lips									
Axial spacing	$s_{l,v}$	[mm]		81,6		100		110	
Characteristic resistance	$V^0_{Rk,s,l,y}$	[kN]	carbon	20,4	41,3	31,1	71,6	57,7	76,8
			stainless	20,4	41,3	31,1	71,6	57,7	76,8
Partial safety factor	$\gamma_{Ms,l}^{1)}$	[-]	carbon/ stainless	1,8					

¹⁾ In absence of other national regulations

GL LOCATELLI anchor channels (GP) with channel bolts (V) and smart anchor channels (HGP)

Performances – Characteristic resistance under static and quasi-static shear loading

**Annex C2/2
of ETA N° 17/0869**

Table C7: Characteristic resistance under static and quasi static shear loading in longitudinal channel axis – steel failure

Anchor channel			Steel	GP 40/223	HGP 40/223	GP 50/30	HGP 50/30	GP 54/33	HGP 54/33	
Steel failure - channel lips/channel bolt										
Characteristic resistance	$V_{Rk,s,l,x}$	[kN]	carbon		- ¹⁾	- ¹⁾	- ¹⁾	- ¹⁾	- ¹⁾	- ¹⁾
			stainless	A2	- ¹⁾	- ¹⁾	- ¹⁾	- ¹⁾	- ¹⁾	- ¹⁾
				A4	- ¹⁾	- ¹⁾	- ¹⁾	- ¹⁾	- ¹⁾	- ¹⁾
Installation factor	γ_{inst}	[-]	carbon/ stainless		- ¹⁾					
Steel failure - anchor										
Characteristic resistance	$V_{Rk,s,a,x}$	[kN]	carbon		12,1		18,8		36,9	
			stainless	A2	16,3		25,4		- ²⁾	
				A4	16,3		25,4		49,9	
Steel failure - Connection channel/anchor										
Characteristic resistance	$V_{Rk,s,c,x}$	[kN]	carbon		10,2		15,6		28,9	
			stainless	A2	12,2		18,7		- ²⁾	
				A4	12,2		18,7		34,6	

1) No performance assessed

2) product not available

**GL LOCATELLI anchor channels (GP) with channel bolts (V)
and smart anchor channels (HGP)**

Performances – Characteristic resistance under static and quasi-static shear loading

**Annex C2/3
of ETA N° 17/0869**

Table C8: Characteristic resistance under static and quasi static shear loading – concrete failure

Anchor Channel		GP40/223 HGP40/223	GP50/30 HGP50/30	GP54/33 HGP54/33
Pry out failure				
Product factor	k_8		2,0	
Partial safety factor	$\gamma_{Mc}^{1)}$		1,5	
Concrete edge failure				
Product factor k_{12}	$k_{cr,v}$		7,5	
	$k_{ucr,v}$		10,5	
Partial safety factor			1,5	

1) In absence of other national regulations

Table C9: Characteristic resistance under combined tension and shear load

Anchor channel		GP40/223 HGP40/223	GP50/30 HGP50/30	GP54/33 HGP54/33
Steel failure – Flexure of channel lips and of channel				
Product factor	k_{13}	[-]	1,0	
Steel failure – Anchor and Connection anchor/channel				
Product factor	k_{14}	[-]	1,0	

**GL LOCATELLI anchor channels (GP) with channel bolts (V)
and smart anchor channels (HGP)**

Performances – Characteristic resistance under static and quasi-static shear loading

**Annex C2/4
of ETA N° 17/0869**

Table C10: Characteristic resistance under fatigue tension load – fatigue resistance to steel failure of the whole system (design method A1 according to EAD 330008-03-0601)

Anchor channel		HGP50/30
Steel failure	n	$\Delta N_{Rk,s,0,n}$ [kN]
Characteristic resistance under fatigue tension load without static preload	$\leq 10^4$	17,95
	$\leq 5 \cdot 10^4$	10,75
	$\leq 10^5$	8,35
	$\leq 5 \cdot 10^5$	4,56
	$\leq 10^6$	3,60
	$\leq 3 \cdot 10^6$	2,69
	$\leq 6 \cdot 10^6$	2,38
	$< 10^7$	2,24

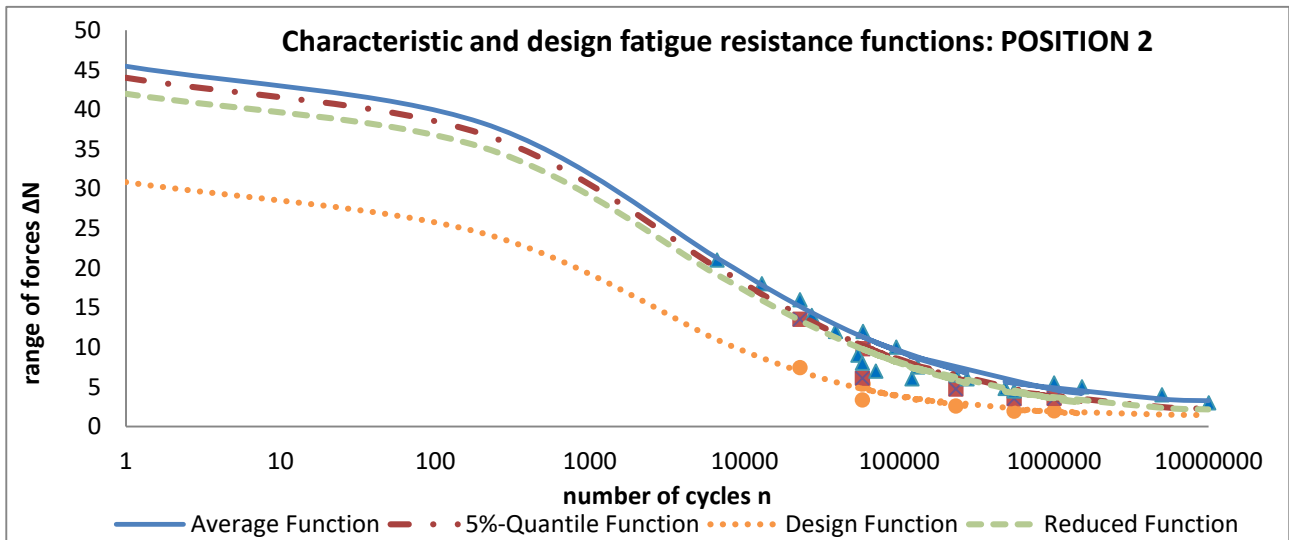

Table C11: Characteristic resistance under fatigue tension load with $n \rightarrow \infty$ load cycles without static preload ($N_{ED}=0$) (design method A1 according to EAD 330008-03-0601) –Steel failure

Anchor channel		HGP50/30
Steel failure		
$\Delta N_{Rk,s,0,\infty}$	[kN]	2,24

GL LOCATELLI anchor channels (GP) with channel bolts (V) and smart anchor channels (HGP)

Performances – Characteristic resistance under fatigue tension loading

**Annex C3/1
of ETA N° 17/0869**

Table C12: Characteristic resistance under fatigue tension load – pullout failure with n load cycles without static preload ($N_{ED}=0$) (design method A1 according to EAD 330008-02-0601)

Anchor channel		HGP50/30
Pullout failure	n	$\Delta N_{Rk,p,0,n}$ [kN]
Characteristic resistance under fatigue tension load in cracked concrete C12/15 without static preload	$\leq 10^4$	24,73
	$\leq 5 \cdot 10^4$	23,03
	$\leq 10^5$	22,33
	$\leq 5 \cdot 10^5$	20,79
	$\leq 10^6$	20,16
	$\leq 3 \cdot 10^6$	19,20
	$\leq 6 \cdot 10^6$	18,62
	$< 10^7$	18,20

Table C13: Reduction factor with n load cycles without static preload ($N_{ED}=0$) (design method A1 according to EAD 330008-02-0601)

Anchor channel		HGP50/30
Concrete cone failure	n	$\eta_{k,c,fat}$ [-]
Reduction factor for $\Delta N_{Rk,c,0;n} = \eta_{k,c,fat} N_{Rk,c}$ with $N_{Rk,c}$ calculated according to EOTA TR047	$\leq 10^4$	0,736
	$\leq 5 \cdot 10^4$	0,685
	$\leq 10^5$	0,665
	$\leq 5 \cdot 10^5$	0,619
	$\leq 10^6$	0,600
	$\leq 3 \cdot 10^6$	0,571
	$\leq 6 \cdot 10^6$	0,554
	$< 10^7$	0,542

Table C14: Characteristic resistance under fatigue tension load with $n \rightarrow \infty$ load cycles without static preload ($N_{ED}=0$) (design method A1 according to EAD 330008-02-0601) – Concrete failure

Anchor channel		HGP50/30
Concrete cone and pullout failure		$\eta_{k,c,fat}$
$\Delta N_{Rk,c,0,\infty} = \eta_{k,c,fat} N_{Rk,c}$	[-]	0,5
$\Delta N_{Rk,p,0,\infty} = \eta_{k,c,fat} N_{Rk,p}$		

GL LOCATELLI anchor channels (GP) with channel bolts (V) and smart anchor channels (HGP)

Performances – Characteristic resistance under fatigue tension loading

**Annex C3/2
of ETA N° 17/0869**

Table C15: Displacement under tension load

Anchor channel			GP40/223 HGP40/223	GP50/30 HGP50/30	GP54/33 HGP54/33
Tension load	N	[kN]	9,5	11,1	20,4
Short time displacement	δ_{N0}	[mm]	0,3	0,2	0,2
Long time displacement	$\delta_{N\infty}$	[mm]	0,6	0,4	0,4

Table C16: Displacement under shear load

Anchor channel			GP40/223 HGP40/223	GP50/30 HGP50/30	GP54/33 HGP54/33
Shear load in transverse direction	V_y	[kN]	9,5	11,1	20,4
Short time displacement	$\delta_{V,y,0}$	[mm]	0,3	0,2	0,2
Long-time displacement	$\delta_{V,y,\infty}$	[mm]	0,5	0,3	0,3
Shear load in longitudinal direction	V_x	[kN]	-1)	-1)	-1)
Short time displacement	$\delta_{V,x,0}$	[mm]	-1)	-1)	-1)
Long-time displacement	$\delta_{V,x,\infty}$	[mm]	-1)	-1)	-1)

¹⁾ No performance assessed

**GL LOCATELLI anchor channels (GP) with channel bolts (V)
and smart anchor channels (HGP)**

Performances – Displacements

**Annex C4
of ETA N° 17/0869**

Table C17: Characteristic resistance under fire exposure – concrete failure

Anchor channel				GP40/223 HGP40/223	GP50/30 HGP50/30	GP54/33 HGP54/33
Concrete cone failure						
Characteristic resistance under fire exposure in concrete C20/25 to C50/60	$N_{Rk,c,fi}^0$	[kN]	R90	6,8	10,6	53,6
			R120	5,5	8,5	42,9

Table C18: Characteristic resistance under fire exposure – pull-out failure

Anchor channel				GP40/223 HGP40/223	GP50/30 HGP50/30	GP54/33 HGP54/33
Pull-out failure						
Characteristic resistance under fire exposure in concrete C20/25 to C50/60	$N_{Rk,p,fi}$	[kN]	R90	7,6	14,0	30,3
			R120	6,1	11,2	24,2

Table C19: Characteristic shear resistance under fire exposure – concrete pry-out failure

Profile			GP40/223 HGP40/223	GP50/30 HGP50/30	GP54/33 HGP54/33
Concrete pry-out failure					
$V_{Rk,cp,fi}$	[kN]	R90	13,6	21,2	107,2
		R120	10,9	16,9	85,8

Table C20: Characteristic shear resistance under fire exposure – concrete edge failure

Profile			GP40/223 HGP40/223	GP50/30 HGP50/30	GP54/33 HGP54/33
Concrete edge failure					
$V_{Rk,c,fi}^0$	[kN]	R90	0,9	1,6	2,3
		R120	0,7	1,3	1,9

GL LOCATELLI anchor channels (GP) with channel bolts (V) and smart anchor channels (HGP)

Performances – Resistance to fire

**Annex C5/1
of ETA N° 17/0869**

Table C21: Characteristic values for tension and shear loads under fire exposure

Anchor channel		GP40/223 HGP40/223	GP50/30 HGP50/30	GP54/33 HGP54/33	
Channel bolts ≥ [mm]		M16	M16	M16	
Steel failure: Anchor, Connection channel/anchor, Local flexure of channel lips					
Characteristic resistance	R90	NPA			
	R120				
Concrete cone failure					
Characteristic edge distance	$C_{cr,N,fi}$	[mm]	138	163	300
	$C_{min,fi}$		300	300	300
Characteristic spacing	$S_{cr,N,fi}$	[mm]	276	326	600
	$S_{min,fi}$		95	90	120

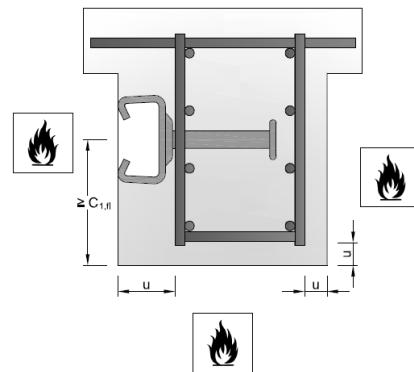
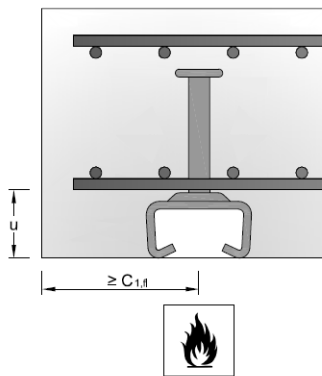

GL LOCATELLI anchor channels (GP) with channel bolts (V) and smart anchor channels (HGP)

Performances – Resistance to fire

**Annex C5/2
of ETA N° 17/0869**