



GL LOCATELLI
Sistemi di Ancoraggio

Catalogo generale
General catalogue



ETA17/0869

Anchor channels



GL Locatelli nasce nel 1972 e ai nostri clienti offriamo tutta la nostra competenza, che si è affinata in 50 anni di attività nella produzione dei sistemi di ancoraggio.
Siamo una piccola società che fa ricerca con le grandi università.

GL Locatelli è l'unico produttore di ancoraggi che dimostri la validità dei profili a freddo anche per ancoraggi con carichi a fatica.

GL Locatelli propone i sistemi più innovativi pensati per le tue esigenze. La nostra struttura flessibile può offrire soluzioni artigianali ottimizzate sulle tue necessità.

Gli algoritmi dei nostri software sono affidabili, verificati, ed i parametri conformi allo standard europeo.

Ci interessa la tua sicurezza in cantiere e vogliamo incontrarti ogni volta che dovrai eseguire un ancoraggio.

GL Locatelli was born in 1972 and we offer to our customers all our expertise, which has been refined in 50 years of activity in the production of anchoring systems.
We are a small company engaged in doing research with major universities.

GL Locatelli is the only manufacturer of anchors which show the validity of cold rolled profiles for fatigue loads, too.

GL Locatelli offers the most innovative systems designed for your needs. Our flexible structure can offer customized solutions tailored to your needs.

Our software algorithms are reliable, verified and parameters comply with the European standard.

We care about your safety on the building yard and we want to meet you every time you have to carry out an anchor.

In copertina:
Bosco verticale a Milano
winner 2014 International Highrise Awards

Front page:
Bosco verticale in Milan
winner 2014 International Highrise Awards







Referenze

References

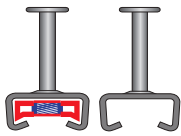
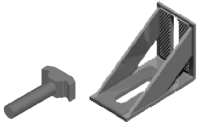
www.adermalocatelli.it

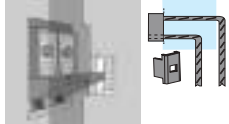

indice index

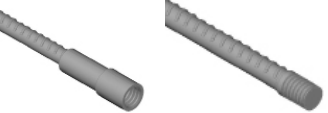
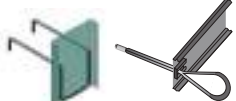
		4
		25
		39
		44
		53
		66
		71
		75
		77

Palazzo Diamante a Milano
Diamond Tower in Milan

Profili di ancoraggio HGP e GP acciaio e acciaio inox

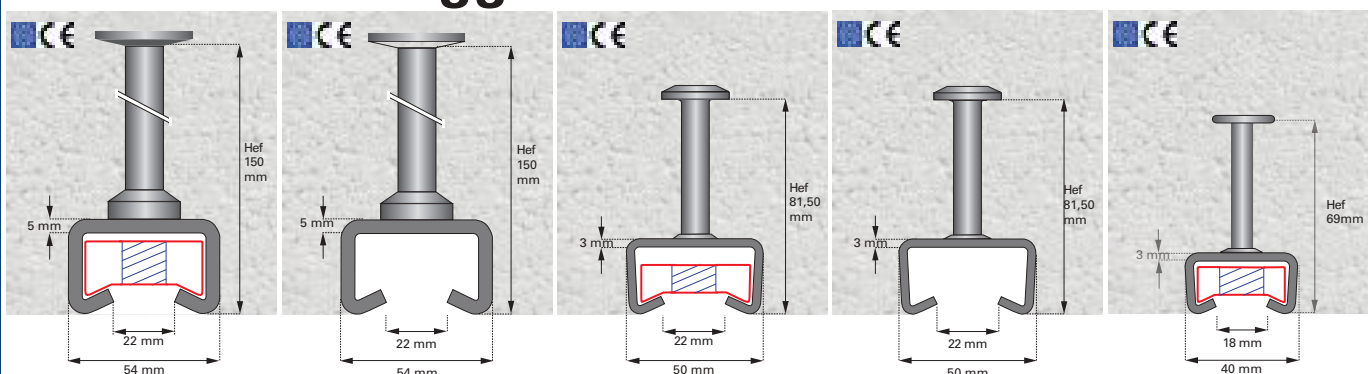

HGP 54/33	GP 54/33	HGP 50/30	GP 50/30	HGP 40/223
N_{RD} 42,6 kN	N_{RD} 32,05 kN	N_{RD} 17,2 kN	N_{RD} 17,2 kN	N_{RD} 11,1 kN
V_{RD} 42,6 kN	V_{RD} 32,05 kN	V_{RD} 39,7 kN	V_{RD} 17,2 kN	V_{RD} 22,9 kN

HGP smart anchor

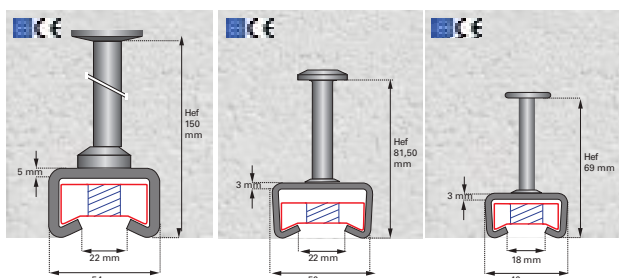

HGP 54/33	HGP 50/30	HGP 40/223
N_{RD} 42,6 kN	N_{RD} 17,2 kN	N_{RD} 11,1 kN
V_{RD} 42,6 kN	V_{RD} 39,7 kN	V_{RD} 22,9 kN

due componenti in un solo prodotto
two components in one product

GP

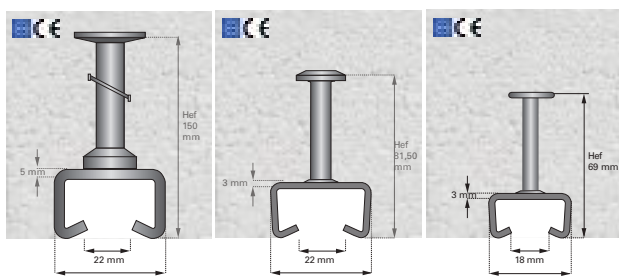

GP 54/33	GP 50/30	GP 40/223
N_{RD} 32,05 kN	N_{RD} 17,2 kN	N_{RD} 11,1 kN
V_{RD} 32,05 kN	V_{RD} 17,2 kN	V_{RD} 11,1 kN

profilo + vite ad ancora channel + T-bolt

GP seismic

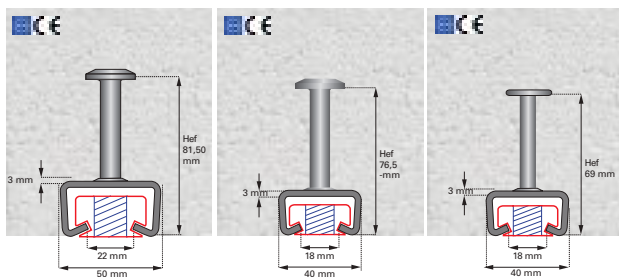

GP 50/30	GP 40/30	GP 40/15
N_{RD} 48,57 kN	N_{RD} 36,06 kN	N_{RD} 15 kN
V_{RD} 30,65 kN	V_{RD} 30,90 kN	V_{RD} 15 kN

ancoraggio scorrevole sliding anchor

HGP and GP Anchor channels steel and stainless steel

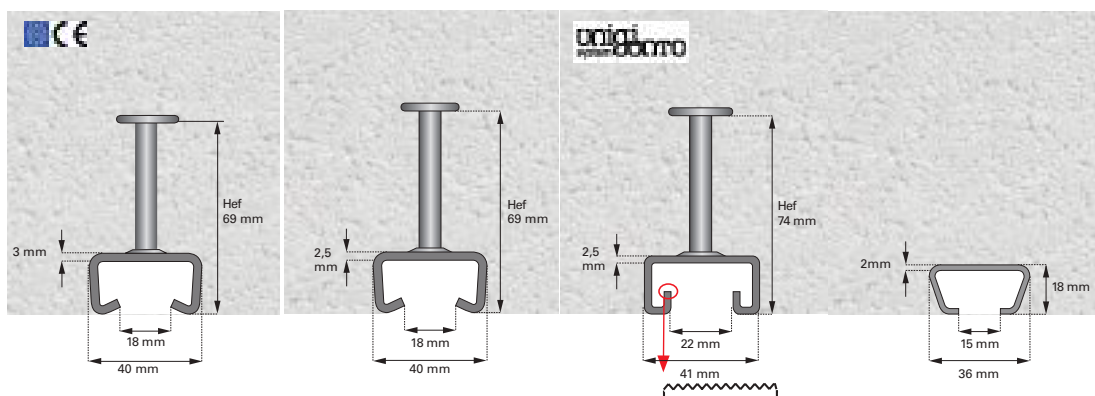

GP 40/223	GP 40/221	GPK2	GL1
N_{RD} 11,1 kN	N_{RD} 10,0 kN	N_{RD} 10,0 kN	N 5,2 kN
V_{RD} 11,1 kN	V_{RD} 10,0 kN	V_{RD} 10,0 kN	V 5,2 kN

Fissaggio Impianti HVAC Fixing

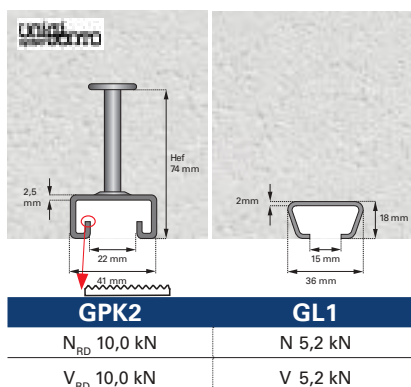

profilo di ancoraggio + accessori per
staffaggio impianti
anchor channel + HVAC accessories

Speciali Special

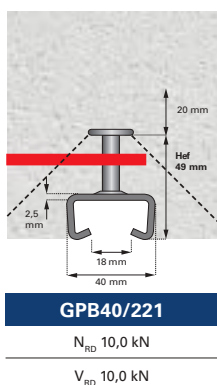

necessità di armatura
supplementare in cantiere
needs additional steel reinforcement
on site

Profili di ancoraggio **HGP smart anchor channel**

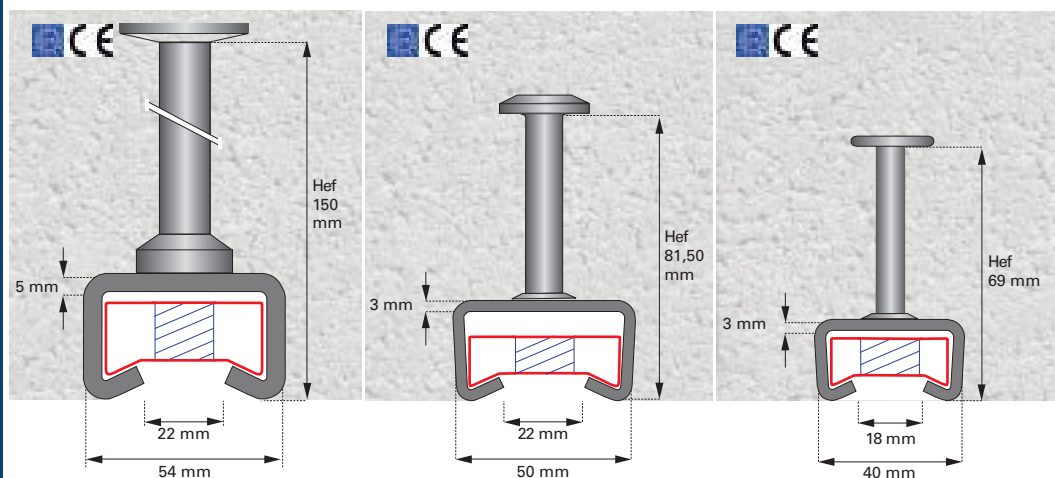

HGP 54/33	HGP 50/30	HGP 40/223
N_{RD} 42,6 kN	N_{RD} 17,2 kN	N_{RD} 11,1 kN
V_{RD} 42,6 kN	V_{RD} 39,7 kN	V_{RD} 22,9 kN



HGP 54/33		HGP 50/30		HGP 40/223	
Lunghezza Lenght	Chiodi Anchors	Lunghezza Lenght	Chiodi Anchors	Lunghezza Lenght	Chiodi Anchors
250	2	250	2	250	2
300	2	300	2	305	2
350	3	375	3	375	3
550	3	500	3	500	3
1000	5	1000	6	1000	5
3000	13	3000	14	3000	14
6000	25	6000	25	6000	25

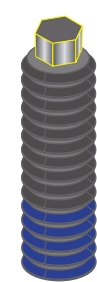

Accessori - Accessories		
	H-bolt	
	H-bolt	

Software GP Anchor Calculation

Il software GP Anchor Calculation consente di scegliere l'ancoraggio, sulla base dei carichi di progetto e sulle condizioni del calcestruzzo circostante. GP Anchor Calculation è scaricabile gratuitamente da www.anchorchannels.com

Software GP Anchor Calculation

GP Anchor Calculation software permits the selection of the anchorage system, based on the design loads and the condition of the concrete around it. You can download GP Anchor Calculation for free at www.anchorchannels.com



HGP smart anchor channel

Tranquillità per il progettista

HGP assicura al progettista che il prodotto che giunge in cantiere è completo. Il lavoro di progettazione fatto con il software di calcolo GP Anchor Calculation è salvaguardato. La relazione di calcolo indica le condizioni del progetto e le prestazioni dell'ancoraggio sono assicurate. Il prodotto è ETA-CE e le prestazioni sono garantite anche con l'uso di barre filettate standard.

L'installatore non deve osservare "raccomandazioni fondamentali" alla salvaguardia del progetto e del marchio CE, come avviene con l'uso degli ancoraggi tradizionali. GP Anchor Calculation è scaricabile da www.anchorchannels.com

Elevate prestazioni a taglio

HGP consente di ottenere elevati carichi a taglio Vrd. Confrontando i carichi in kN dei Vrd dei profili GP con i Vrd dei profili HGP l'incremento è significativo. HGP è molto più prestante e supera anche i carichi Vrd dei tradizionali profili laminati a caldo. In caso di sovraccarico l'ancoraggio si deforma, ma il dado H non esce dal profilo.

Accessori

H-bolt è una barra filettata classe 8.8 M16 con esagono esterno e colla blu anti-svitamento. E' un accessorio molto interessante per assicurare tempi di installazione brevissimi. L'esagono entra nell'avvitatore e in una frazione di secondo il filetto di H-bolt è saldamente nel filetto del dado H. In cantiere ci sono spesso diverse necessità e il fissaggio del dado H può avvenire con una barra filettata o un bullone standard. Unico vincolo è rispettare il passo M16. In questo modo non è più necessario approvvigionare il cantiere con speciali Viti Testa ad Ancora caratterizzate da innumerevoli tipologie per dimensioni della testa, diametri e lunghezze.

Pace of mind for the designer





HGP assures the designer that the product delivered to the construction site is complete. The work done with GP Anchor Calculation software is maintained. The calculation report indicates the design conditions, and the anchorage system performance is ensured. The product is ETA-CE marked and performance is also ensured by the use of standard threaded bars. The installer has not to follow "fundamental recommendations" to preserve the design and the CE marking, as requested when using traditional anchorage systems. You can download GP Anchor Calculation for free at www.anchorchannels.com

High shear performance

HGP permits to obtain high Vrd shear loads. The increase is significant when comparing the Vrd kN loads of GP channels and the Vrd values of HGP channels. HGP is far more performing and overcomes the Vrd loads of the traditional hot laminated channels. The anchorage system goes out of shape in case of overloading, while the H-nut does not exit the channel.

Accessories

The H-bolt is an 8.8 M16 Class threaded bar with external hexagon and blue anti-loosening glue. It is a very interesting accessory to ensure very short installation times. The hexagon enters the electric screwdriver and – in a fraction of a second – the H-bolt is firmly set in the thread of the H-nut. You may often have different needs on the construction site and fastening the H-nut can be achieved by a threaded bar or a standard bolt. The only constraint you have is to keep M16 pitch. This way you no longer need to provide the construction site with special anchor headed screws featuring many types of head sizes, diameters, and lengths.

H-bolt					
Codice	Misura	Peso	Conf.		
Code	Size/Taille	Weight	Pack.		
	M	Kg/um	N°		
HGPZ16	16x60	0,1128	150		
HGPZ1670	16x70	0,1258	100		
HGPZ1680	16x80	0,1386	100		

Profili di ancoraggio GP acciaio e acciaio inox

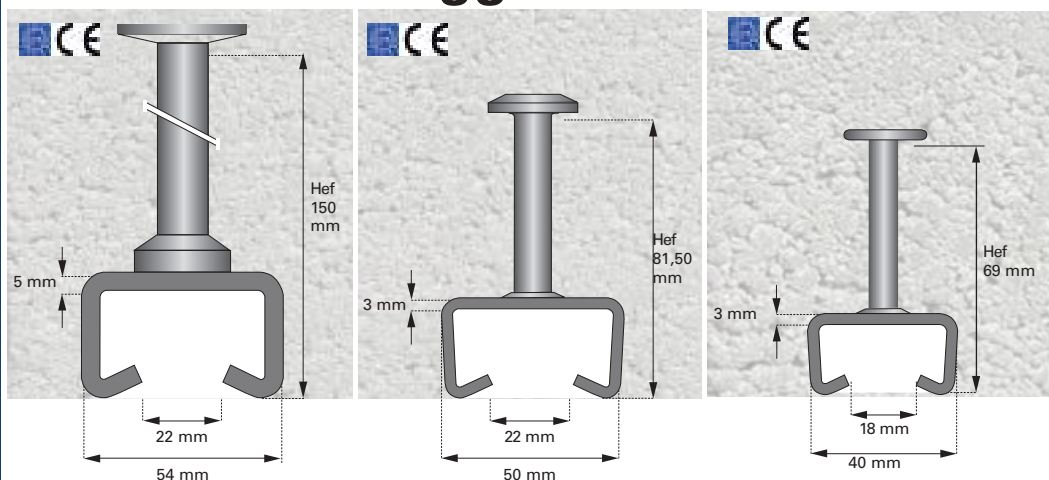

GP 54/33	GP 50/30	GP 40/223
N_{RD} 32,05 kN	N_{RD} 17,2 kN	N_{RD} 11,1 kN
V_{RD} 32,05 kN	V_{RD} 17,2 kN	V_{RD} 11,1 kN

GP 54/33		GP 50/30		GP 40/223	
Lunghezza Lenght	Chiodi Anchors	Lunghezza Lenght	Chiodi Anchors	Lunghezza Lenght	Chiodi Anchors
250	2	250	2	250	2
300	2	300	2	305	2
350	3	375	3	375	3
550	3	500	3	500	3
1000	5	1000	6	1000	5
3000	13	3000	14	3000	14
6000	25	6000	25	6000	25

Accessori - Accessories		
 Viti - T Bolt V50/300 M16 - M20	 Viti - T Bolt V50/300 M16 - M20	 Viti - T Bolt V40/22 M12 - M14 - M16
 R510 M8 - M10	 R510 M8 - M10	 R42 M8 - M10 - M12
 Barre filettate Threaded bars		

Software GP Anchor Calculation

Il software GP Anchor Calculation consente di scegliere l'ancoraggio, sulla base dei carichi di progetto e sulle condizioni del calcestruzzo circostante. GP Anchor Calculation è scaricabile gratuitamente da www.anchorchannels.com

Software GP Anchor Calculation

GP Anchor Calculation software permits the selection of the anchorage system, based on the design loads and the condition of the concrete around it. You can download GP Anchor Calculation for free at www.anchorchannels.com



GP Anchor channels

Sistema tradizionale di ancoraggio composto dal profilo e dalla vite ad ancora.
 E' fondamentale l'uso di viti V40/22 e V50/300 per ottenere le prestazioni indicate dal calcolo. L'impiego di viti ad ancora diverse da V40/22 e V50/300 compromette le prestazioni dell'ancoraggio, il quale perde il DoP ed il certificato CE del prodotto.

Traditional anchorage system made of a channel and an anchor screw. The use of V40/22 and V50/300 screws is fundamental to achieve the performance showed by the calculation. The use of anchor screws different from V40/22 and V50/300 screws may compromise the performance of the anchorage system that loses the DoP and the product CE certificate.

Zincature profili				
Zincatura	Durabilità	54/33	50/30	40/223
Sendzimir	zincatura a caldo del processo coils sendzimir		●	●
A caldo HDG	zincatura per immersione del prodotto nello zinco	●	●	●
Inox 316 - A4	acciaio inox 316 - A4	●	●	●

Galvanized anchor channels				
Galvanized	Durability	54/33	50/30	40/223
Sendzimir	hot dip galvanizing of coils sendzimir processing		●	●
HDG	zinc plating by immersion of the product in zinc	●	●	●
Stainless steel	stainless steel 316 - A4	●	●	●

GP Sismico

GP Seismic

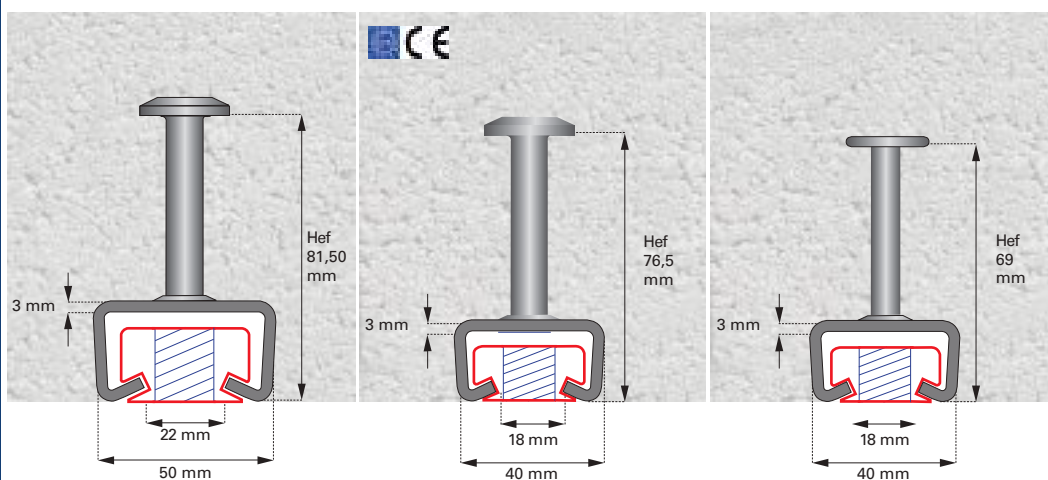

GP50/30	GP40/30	GP40/15
N_{RD} 48,57 kN	N_{RD} 36,06 kN	N_{RD} 15 kN
V_{RD} 30,65 kN	V_{RD} 30,90 kN	V_{RD} 15 kN

GP50/30		GP40/30		GP40/15		Prestazioni cinematiche
Lunghezza Length	Chiodi Anchors	Lunghezza Length	Chiodi Anchors	Lunghezza Length	Chiodi Anchors	Cinematic Performance
250	3	250	3	250	3	$d = \pm 100$ mm
375	4	375	4	375	3	$d = \pm 150$ mm
500	5	500	5	500	4	$d = \pm 200$ mm

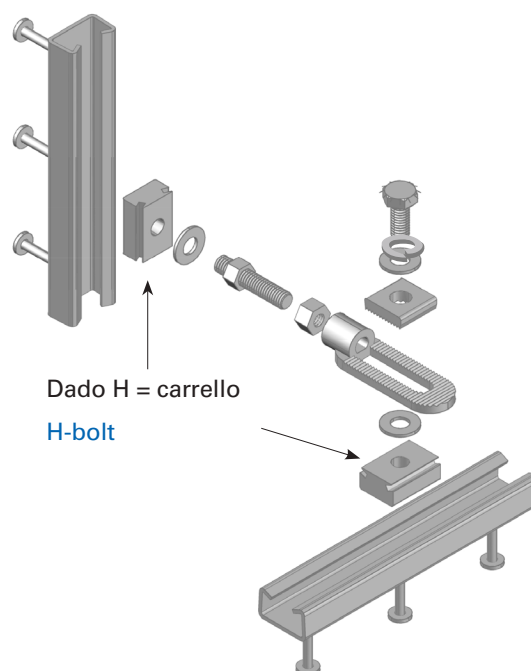
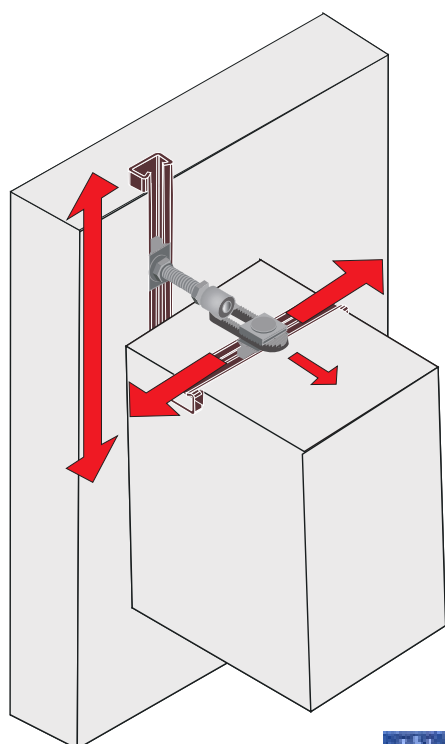

GP Sismico

Ancoraggio scorrevole

GP Sismico nasce dall'esperienza del terremoto del L'Aquila, Italia 2009. Questo ancoraggio consente il fissaggio di pannelli prefabbricati in calcestruzzo alla struttura dell'edificio. Il principio progettuale si basa sul collegamento di due elementi, pannello e struttura, tramite due carrelli che consentono al nodo la libertà di spostamento nelle diverse direzioni addotte dal sisma. Durante il terremoto GP Sismico consente ampi spostamenti della trave rispetto al pannello impedendo la rottura dell'ancoraggio e la caduta del pannello. L'ancoraggio è idoneo per pannelli verticali e orizzontali. GP Sismico è stato oggetto di una ricerca all'avanguardia completata da una campagna di prove che hanno impiegato fra gli altri, l'uso dell'accelerogramma del terremoto di Norcia del 2016 e accelerogrammi USA.

GP Sismico è conforme all'NTC 7.4.5.2 "In tutti i casi, i collegamenti devono essere in grado di assorbire gli spostamenti relativi e di trasferire le forze risultanti dall'analisi, con adeguati margini di sicurezza."

GP Seismic

Sliding anchors

GP Seismic comes from the experience of the 2009 earthquake at L'Aquila, Italy. This anchorage system permits to fix prefabricated concrete panels to the building structure. The design principle is based on the connection of two elements, panel and structure, by mean of two constraint carriages that allow the joint to freely move in the directions caused by the earthquake. During the earthquake, GP Seismic permits wide movements of the girder with respect to the panel, thus preventing the anchorage system from breaking and the panel from falling off. The anchorage system is suitable for vertical and horizontal panels. GP Seismic was assessed by a state-of-the-art research, supported by a test campaign that involved, among other things, the use of the accelerogram of the 2016 earthquake at Norcia and some US accelerograms.

GP Seismic Scomplies with NTC 7.4.5.2 standard. "In all cases connections must be able to absorb the relative movements and transfer the forces resulting from the analysis, with adequate safety margins."

GPSismico - GPseismic							
Codice Code	Tipo Type	Zincatura Galvanized	Lunghezza Length	Chiodi Anchors	Slitta Sleeve	Riempimento Filling	Kg
			mm	N.			
GPZ35125SM	GP sismico 50/30	sendzimir	250	3	1	●	0,89
GPZ45137SM	GP sismico 50/30	sendzimir	375	4	1	●	0,89
GPZ55150SM	GP sismico 50/30	sendzimir	500	5	1	●	1,73
GPZ3422325S10M	GP sismico 40/30	sendzimir	250	3	1	●	0,73
GPZ4422337S10M	GP sismico 40/30	sendzimir	375	4	1	●	0,88
GPZ5422350S10M	GP sismico 40/30	sendzimir	500	5	1	●	1,36
21/09A	GP sismico 40/15	sendzimir	250	2	1	●	0,73
21/09B	GP sismico 40/15	sendzimir	375	3	1	●	0,88
21/09C	GP sismico 40/15	sendzimir	500	3	1	●	1,30
NSGP43	Kit 40	tirante M14x100, dado M14, piastra PXB612 M14, vite TE M14x40, PY6, n. 3 rondelle piane M14, rondella grower M14 threaded rod M14x100, nut M14, plate PXB612 M14, T bolt M14x40, plate PY6, n. 3 plain washer M14, spring washer M14					
NSGP50	Kit 50	tirante M16x100, n.2 dadi M16, piastra PXB612 M16, vite TE M16x40, PY6, n. 3 rondelle piane M16, rondella grower M16 threaded rod M16x100, n.2 nut M16, plate PXB612 M16, T bolt M16x40, plate PY6, n. 3 plain washer M16, spring washer M16					

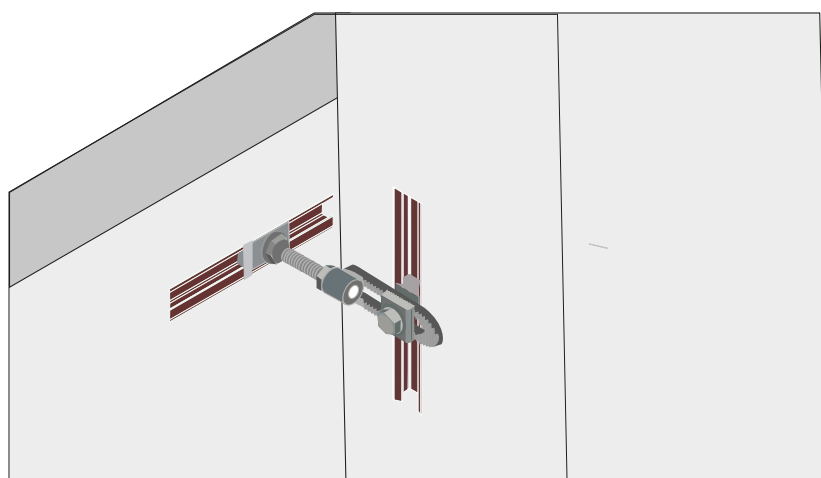
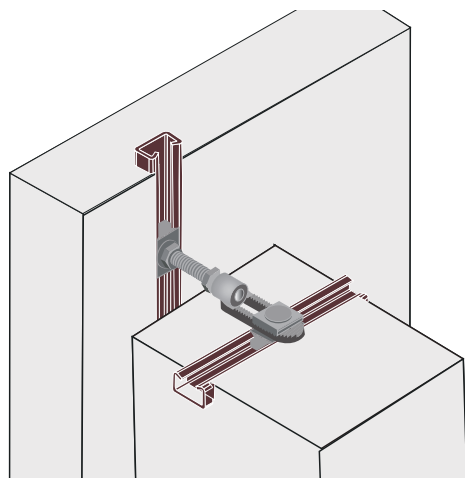

	Piastra LDZS		Plate Plaque LDZS						
Codice zincato Galvanised c.	L	A	B	C	M	E	S1	S2	Peso Weight
	mm	mm	mm	mm	mm	mm	mm	mm	Kg.
PZLDZS	80	100	150	90	17	35	10	8	2,50
PZLDZS2	80	100	180	110	17	35	10	8	2,74

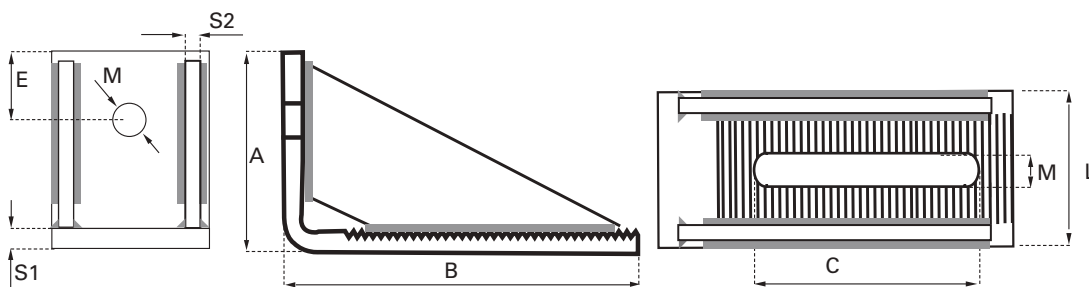
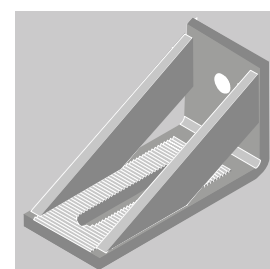

Piastra di compensazione

Qualora sia necessario installare GP Sismico su una trave in calcestruzzo esistente o il GP Sismico si trovi in una posizione non utilizzabile, è disponibile la piastra di compensazione da fissare con tasselli meccanici. Il fissaggio prevede tre tasselli per ciascun lato della piastra. Sulla piastra le asole sono quattro per agevolare il fissaggio. La prescrizione del tassello spetta al progettista.

Post-installable channel

Should it be necessary to install GP Seismic on an existing concrete girder or should GP Seismic be in an unusable position, a compensation plate is available to be fixed by mechanical dowels. Three dowels for each side are needed to fix the plate. The plate has four holes to facilitate fixation. The prescription of the dowels is up to the designer.

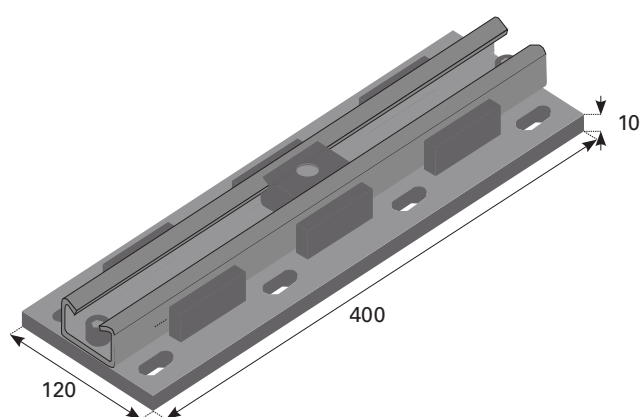

Piastra di compensazione			
Compensation plate Post-installable channel			
Codice zincato	Piastra	Asole	Tasselli
Galvanised c.	Plate/Plaque	Slots	Dowels
	mm.	N.	N.
PS6P43	400x120x10	4+4	Struttura/Structure
PSP6P43	165x120x10	2+2	Pannello/Panel
TS057775	Tassello/Dowel M12x105 ETA-CE		
PSGP43500-8010	500x80x10	4	Tegolo alare/Wing tile
TS058778	Tassello/Dowel M8x80 testa svasata ETA-CE		

Fissaggio impianti

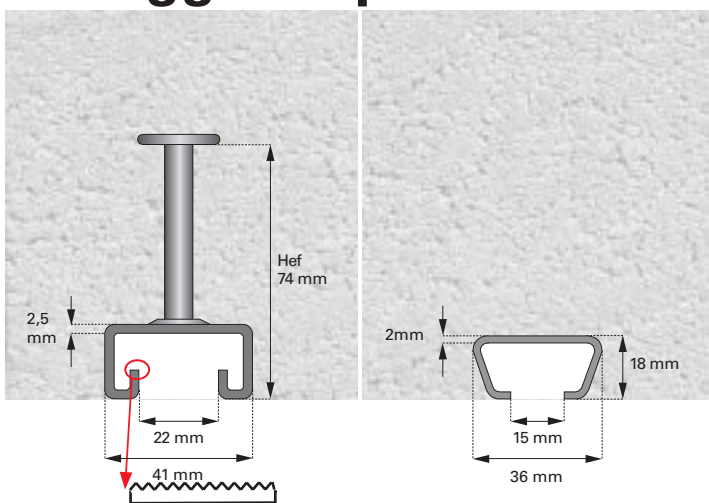

GPK 2	GL1
-------	-----

$N_{RD} = 10,0 \text{ kN}$

$N = 5,2 \text{ kN}$







$V_{RD} = 10,0 \text{ kN}$

$V = 5,2 \text{ kN}$

GPK 2	GL1
-------	-----

Lunghezza Lenght	Chiodi Anchors	Lunghezza Lenght	Chiodi Anchors
1000	5	1000	-
3000	14	3000	-
6000	25	-	-

Accessori - Accessories

 Viti - T Bolt VM4 M8 - M10 - M12	 Viti - T Bolt VM3 M12
 R42 M6 - M8 - M10 - M12	 R7 M6 - M8 / R10 M10
 Rapido / Quick nut M8 - M10 - M12	 Barre filettate threaded bars M6 - M8 - M10
 Rapido a T/ Quick nut M8 - M10 - M12	

Il profilo GPK2 è costruito dal profilo K2 zigrinato, 41x20,5x2,5 mm. di uso comune per l'installazione di impianti idraulici ed elettrici. Il profilo è armato con i chiodi per l'ancoraggio per il calcestruzzo.

GPK2 è completo di riempimento per impedire l'ingresso del calcestruzzo nella fase di getto. Al profilo GPK2 si accoppiano tutti gli accessori impiegati per installare mensole, collari porta tubi, canaline elettriche, pendinature di sottostrutture e cartellonistica.

GL1 con sezione del profilo a trapezio. GL1 trasferisce i carichi al calcestruzzo senza che siano necessarie anche di armatura. Adatto al fissaggio di corpi di illuminazione, cartellonistica, sistemi di rilevazione e sicurezza; il fissaggio avviene tramite viti testa a martello VM3 M12 o tramite piastrine sagomate e barre filettate

HVAC fixing



Unigiunto è una gamma di profili, mensole ed accessori per la rapida installazione di impianti. Scarica il catalogo Unigiunto dal sito www.adermalocatelli.it

Unigiunto is a range of channels, brackets, and accessories for the rapid installation of service systems. Please download the Unigiunto catalogue at: www.adermalocatelli.it

- montaggi veloci
quick assembly
- meno polvere in cantiere
less dust on site
- accessori pag. 29
accessories 29 page

The anchor channel GPK2 built with the toothed anchor channel K2 mm. 41x20,5x2,5 is frequently used for the installation of hydraulic and electrical installation. The channel is reinforced with GP anchors for the anchoring in concrete.

GPK2 is supplied with the filling in order to avoid the entering of the concrete in the cast-in phase. All the accessories used for installing brackets, clamp for pipeline, electrical piping, substructure hangers and posters.

GL1 with trapezium channel section. GL1 transfers the loads to the concrete with no need of reinforcement steel. It suits the fixing of lamps, billboards, detection and security systems. Fixation is achieved by means of VM3 M12 hammer screws or by means of shaped plates and threaded bars.

Profili di Ancoraggio speciali

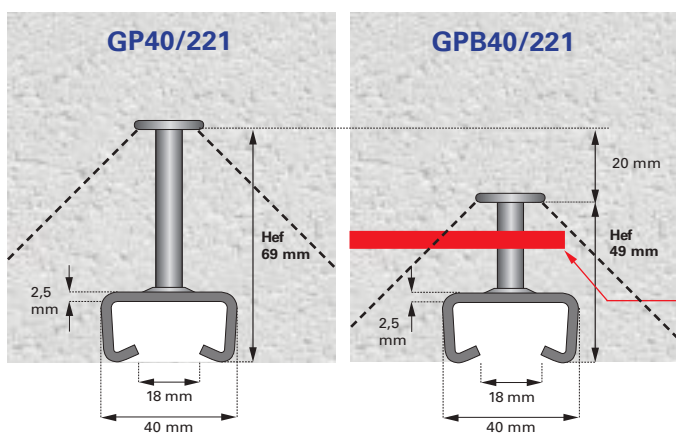

Special GP anchor channel

GPB40/221

N_{RD} 10,0 kN



V_{RD} 10,0 kN

Armatura a cura dell'utilizzatore

Rebar installed by the user.

GP40/221	GPB40/221
N_{RD} 10,0 kN	N_{RD} 10,0 kN
V_{RD} 10,0 kN	V_{RD} 10,0 kN

Accessori - Accessories

 Viti - T Bolt V40/22 M12 - M14 - M16	 Viti - T Bolt V40/22 M12 - M14 - M16
 R42 M8 - M10 - M12	 R42 M8 - M10 - M12
 Barre filettate Threaded bars M8 - M10 - M12	 Barre filettate Threaded bars M8 - M10 - M12

In casi particolari è possibile l'impiego di profili con profondità di ancoraggio ridotte (Hef mm), per consentire l'impiego del profilo all'interno di spessori limitati di cls. Per ottenere la resistenza di ancoraggio indicata a catalogo è necessario integrare con armature supplementari e adeguare la resistenza del calcestruzzo. L'ufficio tecnico GL Locatelli è a disposizione per verifiche e indicazioni. Il dettaglio dell'ancoraggio richiede la prescrizione da parte del progettista.

In special cases lower depth anchor channels (Hef mm) may be used to allow the use of the channel within concrete limited thickness. To achieve the anchoring resistance indicated in the catalogue it is necessary to integrate with supplemental reinforcements and adequate the concrete resistance. GL Locatelli Technical Department is available for checks and indications. The anchorage system detail needs the prescription by the designer.

Ai fini di migliorare la qualità e le prestazioni dei prodotti GL Locatelli, ci riserviamo la facoltà di apportare modifiche senza alcun preavviso.

In the interests of improving the quality and performance of GL Locatelli products, we reserve the right to make specification changes without prior notice.

Certificati di prodotto

Product certifications



European Technical Assessment

ETA 17/0869 Anchor channels HGP - GP
ETA 22/0217 GP Seismic

Environment products Declaration

EPD ITALY 0234
ISO 14025 e EN 1584



Certificati GL Locatelli

GL Locatelli certifications



EN ISO 9001

Quality controlled from ICMQ Italy
First certification 1994 (30 years)



EN 1090 produzione strutture in acciaio EXC3

Classe di esecuzione: il massimo dei requisiti, per edifici strategici, zona sismica, elevata presenza di persone.

EN 1090 steel structures production EXC3

Execution class: top level request in strategic building, seismic area, high people presence .



Factory Production Control

Controllo di fabbrica a 22078 Turate - Italia
Factory production control in 22078 Turate - Italy

I vantaggi nell'uso dei Profili GL Locatelli

- Velocità di fissaggio.
- Regolazione della posizione.
- Non serve personale specializzato.
- HGP - non servono viti speciali.
- HGP - prestazione eccellente per carichi a taglio.
- Profili, viti e accessori sono protetti dalla corrosione tramite zincatura di alta qualità o sono realizzati in acciaio inox.
- Resistenza al fuoco.
- Resistenza per carichi a fatica.
- Resistenza in zone sismiche.
- Riutilizzabile per nuovi fissaggi.
- Serraggio rapido garantito.

The advantage of using GL Locatelli cast-in channels

- Extremely short installation time.
- Installation is freely adjustable along the channel slot (compensation of construction tolerances).
- The installer requires no special training.
- HGP - we can avoid using special bolts.
- HGP - excellent performance for shear loads.
- Components (as channels, bolts and accessories) are protected against corrosion by high-quality galvanized finishing or stainless steel finishing.
- Fire resistance.
- Dynamic loads resistance.
- Resistance in seismic zones.
- Reusable for new fixing.
- Guaranteed quick tightening.



Software di calcolo in www.anchorchannels.com Calculation software into www.anchorchannels.com

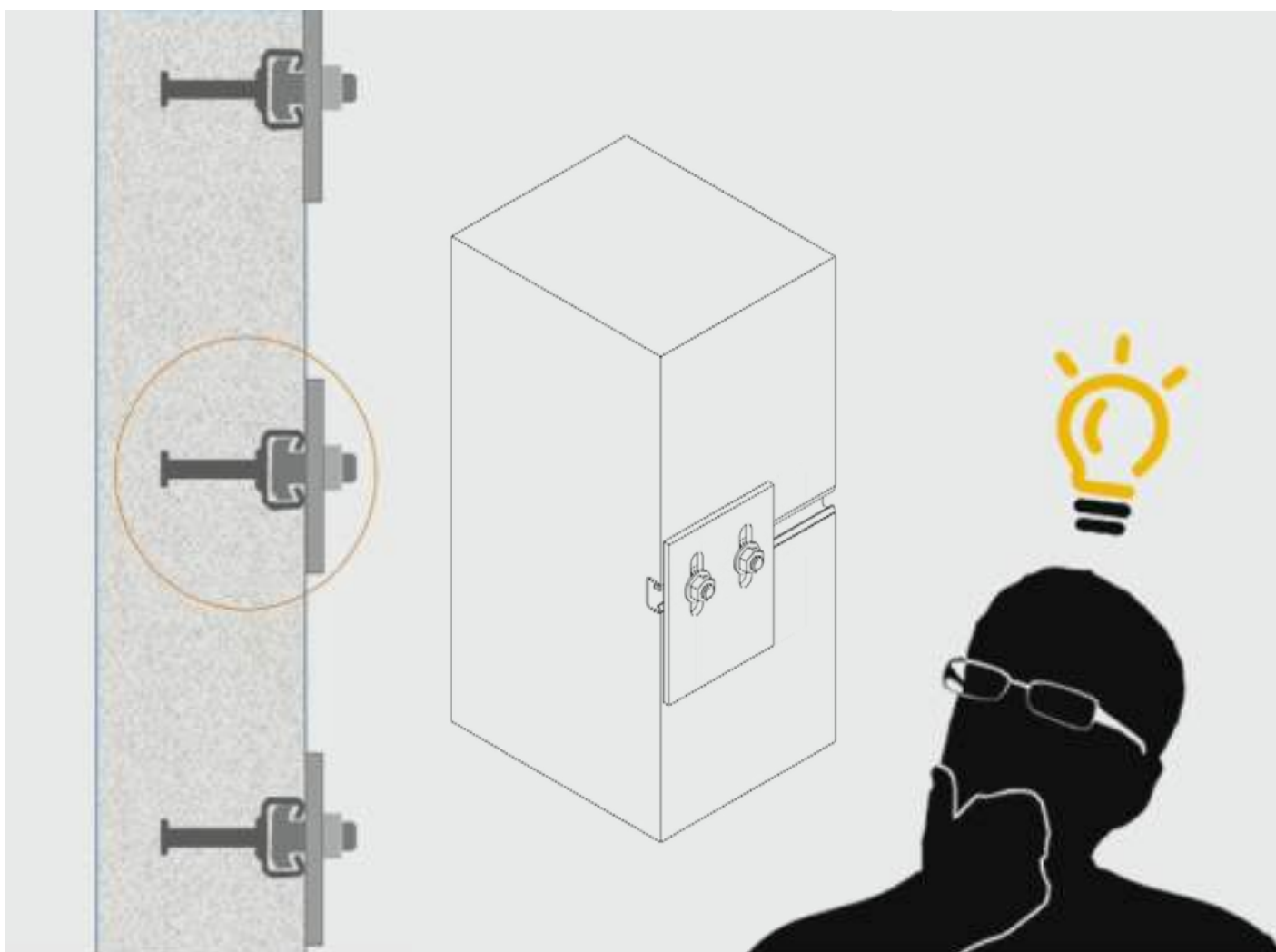

Pericoli nascosti nei metodi alternativi

con l'uso di piastre saldate

- Le scintille delle saldature possono provocare incendi (ponteggi, reti di sicurezza ed ambienti interni).
- La qualità della saldatura dipende esclusivamente dalla persona che la esegue.
- La saldatura chiede tempo e precisione.
- E' necessario un piano di controllo e collaudo dei fissaggi.
- Il controllo delle saldature avviene a campione.
- I fumi possono danneggiare il vetro e l'alluminio provocando danni costosi
- Regolazione limitata.
- Possibili danni alle strutture e rischi di incendio.
- Ogni saldatura deve essere protetta dalla corrosione.
- Utilizzo di attrezzature elettriche pesanti
- Difficoltà di operatività in caso di richieste di modifiche durante il lavoro.
- Eventuali modifiche sono difficili e costose.

con l'uso dei tasselli meccanici o chimici

- Tempo per tracciare le posizioni dei fori.
- Non è regolabile.
- Tempo e fatica per la foratura.
- I fori possono essere posizionati in modo non corretto o risultare troppo grandi a causa di foratura inesatta.
- I fori possono danneggiare la struttura in calcestruzzo tagliando l'armatura e innescando processi di corrosione.
- La posizione errata di bulloni di ancoraggio può portare danni alle piastre di fissaggio.
- Il trapano può provocare vibrazioni, che creano crepe di larghezza e lunghezza indefinita.
- L'uso ripetuto del trapano può causare una serie di problemi come la sindrome da vibrazioni mano-braccio (HAV) con sintomi gravi di dito bianco Fenomeno di Raynaud(VWF).
- Lavoro in ambienti polverosi
- Lunghie procedure di installazione : ogni singolo passo è una possibile fonte di errore umano (in particolare con i bulloni chimici).
- Il controllo visivo dell'installazione non è attendibile.

GL Locatelli si riserva di modificare ed aggiornare in qualsiasi momento le informazioni riportate in questo catalogo per il miglioramento continuo dell'informazione.

Hidden hazards in the alternative methods

when using welded plates

- the sparks of welding can cause fires (scaffolding, safety nets and indoor.)
- The quality of the welding depends solely on the person who performs the operation.
- Welding takes time and precision.
- A plan of control and testing the fixing is needed.
- The weld inspection is carried out randomly.
- The smoke may damage the glass and aluminium causing costly damage.
- Limited adjustment.
- Possible damages to structures and fire hazards.
- Each welding must be protected against corrosion.
- Use of heavy electrical equipment.
- Operational difficulties in case of change requests during the work.
- Any changes are difficult and expensive.

when using mechanical or chemical anchor bolts

- Time to trace the holes location.
- It is not adjustable.
- Time and effort for drilling.
- The holes can be positioned incorrectly or come out to be too large due to inaccurate drilling.
- The holes can damage the concrete structure cutting the reinforcement and triggering corrosion processes.
- The incorrect position of the anchor bolts can cause damages to the fixing plates.
- The driller may cause vibrations, which create indefinite cracks in width and length.
- Repeated used of drills can cause a number of problems such as the syndrome of hand-arm vibration (HAV) with severe symptoms from Vibration-induced white finger syndrome (VWF).
- Work in dusty environments
- Long installation procedures - each step is a possible source of human error (especially with chemical bolts).
- The visual check of installation is not reliable

GL Locatelli reserves the right to modify and update at any time the information provided in this catalog for continuous improvement of information.

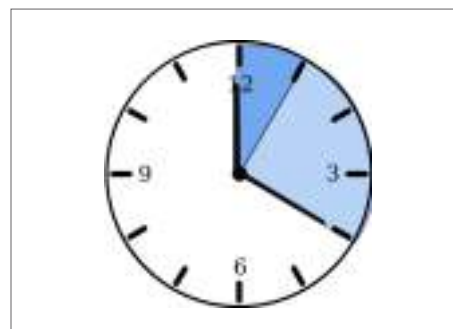

Indicazioni sulle distanze minime tra bordo getto e profilo

La corretta valutazione della distanza minima da porre fra l'asse del profilo e il bordo del getto richiede la conoscenza della resistenza del calcestruzzo e dell'armatura impiegata. Le distanze consigliate sono ricavate dalle prove secondo EAD 330008-02-0601 e conformi ai nostri ETA del 2012 e successivi. Prove realizzate con calcestruzzo C20-25

Posizionare il profilo a filo con la superficie del getto in cls verificando che lo spessore minimo del calcestruzzo sia pari all'ingombro dell'ancoraggio (profilo+ancoraggio) più il copriferro C.

L'uso del profilo in barre rende più veloci le operazioni di inserimento nel cassero riducendo il rischio di spostamenti dovuti alle vibrazioni.

Materiali : profili di ancoraggio Materials: anchor channels		Norma Reference
Materiale Material		Uni
Acciaio S235JR steel		EN10025
Acciaio S420MC steel		EN10149
Inox 304 A2 Stainless steel		EN10088
Inox 316 A4 Stainless steel		EN10088

Distanze minime di posa Minimum installation distances						
Profilo Channel	Profondità di posa = h profilo Depth of laying H=channel	C	Dc	Da	Db	Dd
	mm	mm	mm	mm	mm	mm
HGP54/33	153	30	100	100	200	200
GP54/33	153	30	100	100	200	200
HGP50/30	80	30	75	75	150	150
GP50/30	80	30	75	75	150	150
HGP40/223	72	30	50	50	100	100
GP40/223	72	30	50	50	100	100
GP40/221	72	30	50	50	100	100
GPK2	74	30	50	50	100	100
GL1	18	30	50	50	100	100

Information on the minimum distances between the edge of the concrete element and the anchor channel

The right evaluation of the minimum distance between the anchor channel axis and the edge of the concrete element requires the knowledge of the resistance of concrete and the employed reinforcement.

The recommended distances are obtained from the tests according to EAD 330008-02-0601 and compliant with our 2012 ETA and later versions. The tests have been made with concrete C20-25.

Placing the profile in line with the surface of the concrete element checking that the minimum thickness of concrete is equal to the total height of the anchor channel (given by the sum of the heights of the channel, plus the anchor) and the concrete cover C.

The use of the profile in bars makes the operations of insertion in the formwork faster, reducing the risk of displacement due to vibrations.

Materiali : viti e accessori Materials : screw and accessories		Norma Reference
Materiale Material		Uni
Acciaio S235JR steel		EN898-1
Acciaio S420MC steel		EN898-1
Inox 304 A2 Stainless steel (A2-50 / A2-70)		EN10088
Inox 316 A4 Stainless steel (A4-50 / A4-70)		EN10088

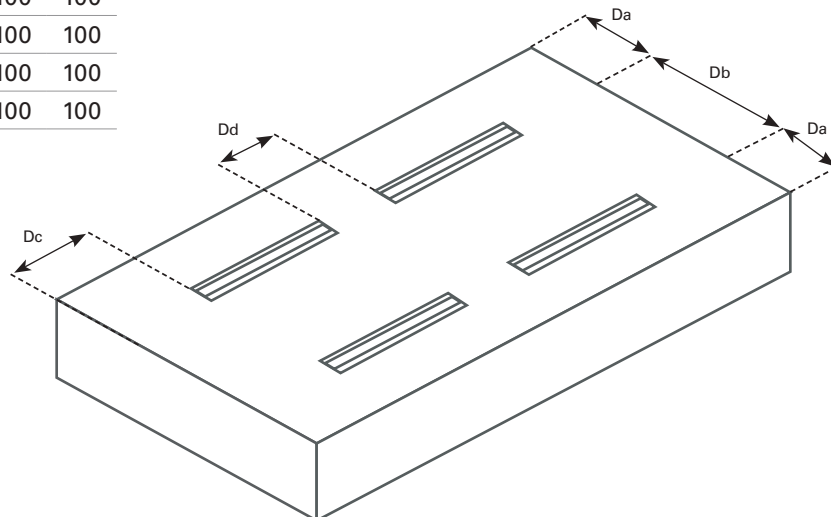
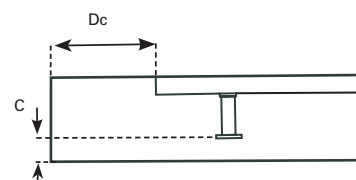

Prestazioni dei profili di ancoraggio

Anchoring channel performances

Carichi di portata dei profili di ancoraggio - Anchor channels loads							
Profilo	Dimensioni	Profondità di posa = h profilo	Carico puntuale a trazione	Carico a Taglio	Zincatura Sendzimir	Zincatura a caldo	Inox 304
Channel	Dimension	Depth of laying	Tensile load	Shear load	Sendzimir Galvanized	Hot Galvanized	Stainless steel A4
	mm	mm	NRD kN	VRD kN			
HGP54/33	54x150x5	153	42,6 kN	42,6 kN		•	•
GP54/33	54x33x5	153	32,05 kN	32,05 kN		•	•
HGP50/30	50x76,5x3	80	17,2 kN	39,7 kN	•	•	•
GP50/30	50x30x3	80	17,2 kN	17,2 kN	•	•	•
HGP40/223	40x69x3	72	11,1 kN	22,9 kN	•	•	•
GP40/223	40x22x3	72	11,1 kN	11,1 kN	•	•	•
GP40/221	40x22x2,5	72	10,0 kN	10,0 kN	•		
GPK2	41x21x2,5	74	10,0 kN	10,0 kN	•		•
GL1	36x18x2	18	5,2 kN	5,2 kN	•		•



Reazione al fuoco classe A1

Le verifiche degli ancoraggi per la resistenza al fuoco possono essere condotte secondo la TRZ20 "Evaluation of anchorages in concrete concerning resistance to fire" Valori caratteristici in ETA 17/0869 annex C6 e C7



Fire reaction A1 class classe A1

The anchor channels about fire resistance verifie are realize on TRZ20 "Evaluation of anchorages in concrete concerning resistance to fire" Caraceteristique value in ETA 17/0869 annex C6 e C7



Carico a fatica

La verifica degli ancoraggi per il carico a fatica è condotta col metodo A1 in accordo con la EAD330008-02-0601 è indicata nell'ETA 17/0869 annex C9- C10

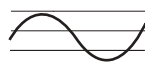

Fatigue tension load

The anchor channel verifie for fatigue tension load, design metod A1 in according to EAD330008-02-0601 is into ETA 17/0869 annex C9- C10

Finitura dei profili e degli accessori

GL Locatelli raccomanda l'impiego di ancoraggi zincati o inossidabili per assicurare una lunga durata. Qualora si ricorresse a materiale non protetto, la durabilita dell'ancoraggio sarà assicurata dal completo annegamento nel calcestruzzo.

Per impieghi in particolari contesti ambientali, si raccomanda l'uso di ancoraggi completamente inossidabili.

In cantiere bisogna proteggere l'ancoraggio inossidabile dal contatto accidentale con altri acciai (meno nobili) per evitare di comprometterne l' inossidabilità.

Attenzione: Prodotti neri o decapati possono essere forniti su richiesta per applicazioni che richiedano la saldatura.

Si sconsiglia l'uso di ancoraggi misti, realizzati con acciai ferrosi e acciai inossidabili.

Finishing of profiles and accessories

GL Locatelli recommends the use of galvanized or stainless anchor channels to ensure a long service life. In case of using non-protected material, the anchor channel durability is ensured by the complete burial in the concrete.

For use in special environmental contexts, the use of fully stainless steel anchors channels is recommended. In the building yard you have to protect the stainless steel anchor channels from accidental contact with other steel (less noble) as this may affect the inoxidazability.

Warning: blacks or pickled products can be supplied on request for applications requiring welding

We do not recommend the use of mixed anchors, made of ferrous and stainless steel.

Zincatura sendzimir, a caldo z/s

Normativa di riferimento UNI EN 10142
 Impiegato sui laminati per la produzione di profili.
 Finitura adatta per ambienti umidi soggetti ad agenti atmosferici.
 Procedimento di protezione a caldo eseguito durante la laminazione dell'acciaio.
 Il nastro di laminazione attraversa una vasca contenente zinco fuso a 700 °C che si deposita sulle superfici conferendo un'ottima protezione al prodotto.
Rivestimento: 275 g/m² (Peso garantito del rivestimento equivalente ad uno spessore di 19-21 µm su ogni faccia)

Zincatura a caldo z/c

Normativa di riferimento UNI EN ISO 1461 e successive modifiche ed integrazioni.
 Finitura adatta per ambienti esterni (preferibilmente non in zone costiere o fortemente inquinate) ed ambienti umidi.
 Rivestimenti di zincatura per immersione a caldo di prodotti finiti ferrosi e articoli in acciaio. Il prodotto, dopo un processo di pulitura e sgrossatura, viene immerso in vasche di zinco fuso ad una temperatura di 450-500 °C.
 Dopo diversi bagni si forma un consistente strato di zinco a protezione dell'acciaio.
 Impiegato per profili e piastre.
Rivestimento: ≥55 µm (Norma: 35÷70 µm spessore minimo locale).

Zincatura elettrolitica z/E

Normativa di riferimento UNI EN ISO 2081.
 Finitura particolarmente indicata per applicazioni in ambienti interni o scarsamente umidi. Procedimento a freddo che sfrutta il processo di elettrolisi.
 Il prodotto viene immerso in diversi bagni acido-alcinali che aumentano la sua conducibilità e favoriscono quindi il deposito di zinco.

Zincatura sherardizzata

Zincatura per piccoli prodotti. Non riguarda i laminati per la produzione di profili.

Acciaio inox AISI304=A2 AISI316=A4

Gli acciai inossidabili sono delle leghe a base di ferro, carbonio, cromo e nichel ed altri elementi in quantità minore che conferiscono al materiale le proprietà meccaniche dell'acciaio oltre ad un'ottima resistenza alla corrosione.
 I profili inox vengono utilizzati in condizioni ambientali particolarmente aggressive (zone fortemente inquinate o costiere ad eccezione di ambienti ricchi di cloruri) nel campo dell'industria chimica, alimentare e farmaceutica.

Sendzimir galvanization, hot

Reference standard UNI EN 10142
 Used on laminates for the production of profiles.
 Suitable finishing for net environments subject to atmospheric agents.
 A hot protection procedure carried out during the rolling of the steel.
 The laminating tape goes through a bath containing melted zinc at 700 °C which goes on the surface giving an excellent protection to the product.
Coating: 275 g/m² (guaranteed equivalent weight of the coating to a thickness of 19-21 µm on each face).

HDG - Hot dip galvanization z/c

Reference standard UNI EN ISO 1461 and subsequent amendments and additions. Finish of suitable for outdoor use (preferably not in coastal or heavily polluted areas) and net environments. Hot dip galvanized coatings on ferrus iron and steel items. After a cleaning and roughing process, the product is immersed in a bath of melted zinc at a temperature of 450-500°C.
 After several baths, a consistent layer of zinc will form to protect the steel. Used for profiles and plates.
Coating: ≥55 µm (Standard: 35÷70 µm local minimum thickness).

Electrolytic galvanization

Reference standard UNI EN ISO 2081
 Finishing particularly suitable for indoor applications or poorly wet environments. Cold process that employs the electrolysis process.
 The product is dipped in several acid-alkaline baths that increase its conductivity and therefore helps the zinc deposit.

Sherardized galvanizing

Galvanized coating for small items. It does not concern the metal sheets bars, for the production of profiles.

Stainless steel AISI304=A2 AISI316=A4

Stainless steel are alloys based on iron, carbon, chromium, nickel and other elements in smaller quantities that give the material the mechanical properties of the steel in addition to an excellent corrosion resistance.
 The steel profiles are used in particularly aggressive environments (heavily polluted or coastal areas with the exception of chloride-rich environments) in the chemical industry, food and pharmaceutical industries.

Finitura - Finiture		
Profili - Anchor channel	Norma - Reference	Spessore W Thickness -
Sendzimir a caldo - Sendzimir hot a Caldo - Hot Dip G.	EN10025 EN10149	275 g/m ² ≥19 µm > 55 µm
Viti - T Bolt		
Elettrolitica - Electrolityc	EN3740/6	≥12 µm > 40 µm

Riempimento

Per mantenere pulito il profilo durante la fase di getto GL Locatelli realizza un riempimento in schiuma di resina sintetica rigida a cellula chiusa ad alta densità. La schiuma viene iniettata in forma liquida all'interno della cavità del profilo espandendosi in tutto il suo volume. Questa tipologia di materiale consente il riempimento integrale del profilo, la sua perfetta planarità con il cassero e l'immediata visibilità nel calcestruzzo. Il prodotto, data la composizione, non richiede particolari accorgimenti nello smaltimento, ma costituisce un semplice rifiuto solido urbano. Il riempitivo è contenuto in una guaina che facilita la rimozione. La guaina porta stampato sul dorso il marchio GL quale ulteriore elemento di garanzia.

Filling

To prevent fouling during the casting phase, GL Locatelli makes a foam filler with high-density, closed-cell, rigid, synthetic resin. This foam is injected in a liquid form into the section's cavity and expands to fill the entire space. This type of material allows the section to be completely filled, perfect flatness with the formwork, and its immediate visibility in the concrete. Due to the composition of the product, it does not require special disposal procedures. It is simply considered as a solid urban waste. The filling is contained in a film which enables its removal. The GL trademark is printed on the back of the film, constituting a further element of guarantee.

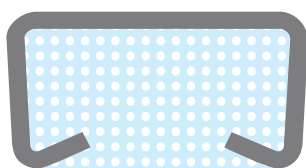

Resina rigida GL
GL rigid resin

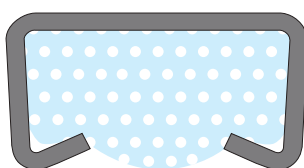

Poliuretano espanso
Foamed polyurethane

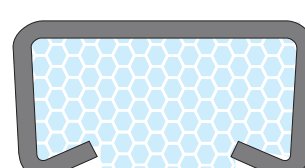

Polistirolo
Polystyrene

MANUALE D'USO USER MANUAL

Installazione in cantiere

Installazione nel cassero dei profili di ancoraggio GP e HGP.

Posizionare il profilo di ancoraggio nel cassero rispettando le distanze minime C1 e C2.

Installation in the building yard

Installation in the formwork of GP and HGP anchor channels

Respecting the minimum distances C1 and C2

Distanza minima dai bordi - mm - Minimum edge distance

Profilo	HGP54/33	HGP50/30	HGP40/223				
Channel	GP54/33	GP50/30	GP40/223	GP40/221	GPK2	GP1	GL1
C1,C2	100	75	50	50	50	50	50

Fissare il profilo affinché rimanga in posizione durante il getto, a scelta: legare alle armature, incollare con silicone, inchiodare al cassero di legno.

Eseguire il getto in calcestruzzo e compattare vibrando.

Fixing the profile in order to have it in position during the concrete pouring, choosing between: binding it to the reinforcement, glue it with silicone or nail it the wooden formwork. Make the concrete casting and vibrate it in order to compact the mix.

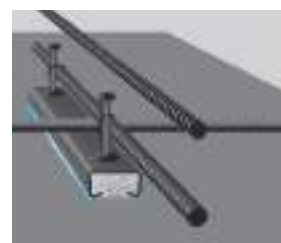
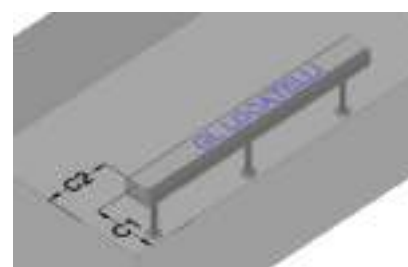
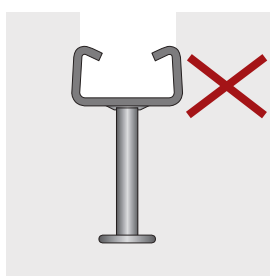
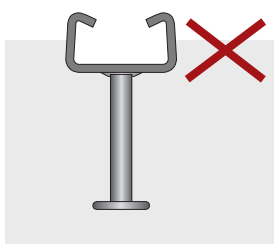
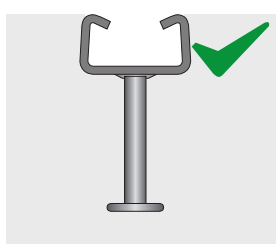

Installazione dell'ancoraggio - Anchorage installation

Rimuovere il riempimento di schiuma dal profilo

Remove the foam filling from the channel

HGP - avvitare la barra filettata M16x60 nel connettore all'interno del profilo. Il grano è completamente avvitato quando il filetto BLU non è più visibile. Eseguire l'ancoraggio con dadi e rondelle piane rispettando la coppia di chiusura M16 SMART ANCHOR
ETA17/0869

HGP - threaded bolt M16x60 socket into the link inside the profile. The sockets are completely screwed when the BLUE thread will disappear. Carry out the fixing with nut and flat washers respecting the M16 torque hammer-head SMART ANCHOR.
ETA17/0869

GP - Inserire la vite testa ad ancora nel profilo e ruotare la vite di 90° in senso orario in modo che la testa si ancori alle estremità del profilo.
ETA17/0869
(non tutti)

GP - Insert the channel bolt into the channel slot and rotate the channel bolt of 90° clockwise in a way that the head anchor itself to the edges of the profile.
ETA17/0869
(not all)

Verificare il corretto posizionamento della vite ad ancora.
La scanalatura presente sotto al gambo della vite deve essere perpendicolare all'asse longitudinale del profilo. Installare le viti a una distanza superiore a 40 mm dall'estremità laterale del profilo GP.
Eseguire l'ancoraggio con dadi e rondelle piane rispettando la coppia di chiusura.

Check the correct positioning of the GL Locatelli hammer-head channel bolt. The groove on the shank end of the channel bolt must be perpendicular to the channel longitudinal axis. Install the channel bolts at a distance higher than 40 mm from the lateral edge of the GP anchor channel.
Carry out the fixing with nuts and flat washers respecting the torque.

L'ancoraggio, la certificazione ETA e le prestazioni sono garantiti esclusivamente con l'uso di profili e viti GL Locatelli.

The anchor system, the ETA certification and the performances are exclusively guaranteed with the use of GL Locatelli profiles and screws

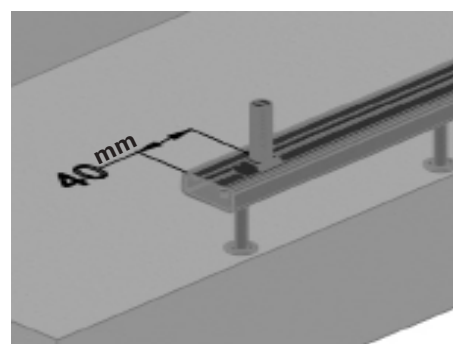
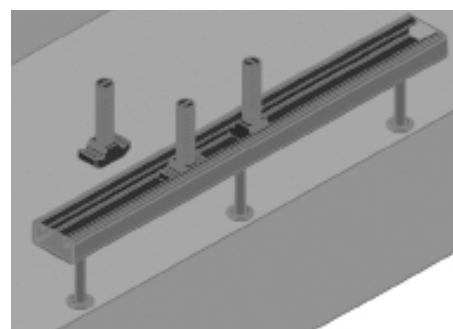
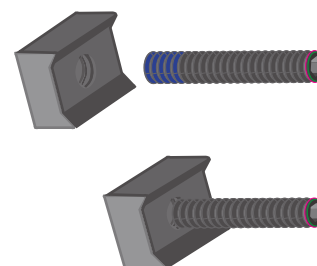

Coppia di serraggio (cls-acciaio) - Tinst Nm - Recommended torque (concrete-steel)										
Profilo Channel	HGP54/33	GP54/33	HGP50/30	GP50/30	HGP40/223	GP40/223	GP40/221	GP38/17	GPK2	GL1
Vite Screw	HGP	V50/300	HGP	V50/300	HGP	V40/22	V40/22	V38/17	VM4	VM3
M 8	-	-	-	-	-	-	-	-	15	-
M 10	-	15	-	15	-	15	15	15	15	15
M 12	-	25	-	25	-	25	25	25	25	25
M 14	-	35	-	35	-	35	35	35	-	-
M 16	60	60	60	60	60	35	35	35	-	-
M 20	-	100	-	60	-	-	-	-	-	-

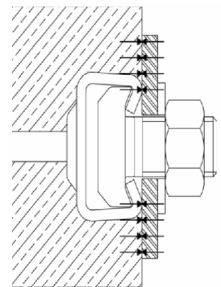

Coppia di serraggio (acciaio-acciaio) - Tinst Nm - Recommended torque (steel-steel)										
Profilo Channel	HGP54/33	GP54/33	HGP50/30	GP50/30	HGP40/223	GP40/223	GP40/221	GP38/17	GPK2	GL1
Vite Screw	HGP	V50/300	HGP	V50/300	HGP	V40/22	V40/22	V38/17	VM4	VM3
M 8	-	-	-	-	-	-	-	-	15	-
M 10	-	15	-	15	-	15	15	15	15	15
M 12	-	25	-	25	-	25	25	25	25	25
M 14	-	35	-	35	-	35	35	35	-	-
M 16	60	60	60	60	60	45	45	45	-	-
M 20	-	120	-	75	-	-	-	-	-	-

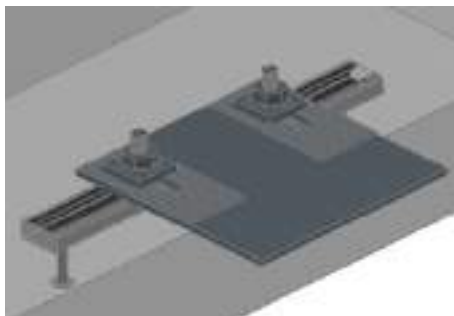
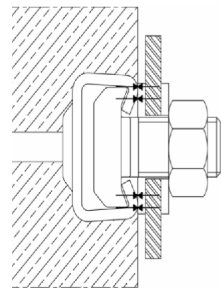

HGP smart anchor per facciate in vetro
 Curtain walling HGP Smart Anchor

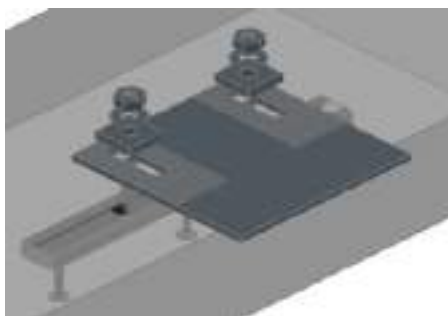

HGP smart anchor esploso
 Details of the HGP Smart Anchor axonométriquement



Ancoraggio pareti - Bosco verticale Milano
 Sideboard - Bosco verticale Milano, Italy



Ancoraggio per rivestimenti di facciata
 Fixing for façade cladding



Facciata in vetro - Reale Mutua Assicurazioni Torino
 Curtain walling - Reale Mutua Assicurazioni, Turin-Italy



Rivestimento dei pilastri - Fond. Feltrinelli Milano
 Cladding of the pillars - Fondazione Feltrinelli Milano-Italy

Viti V28/15

Vite V28/15 testa a martello prodotta in acciaio classe 8.8, finitura zincata secondo UNI ISO 2081 Europea 2002/95 Rohs

Produzioni su richiesta:
acciaio inox AISI 304 e 316
Vite fornita completa di dado

V28/15 M 6 classe 8.8			
Codice	Misura	Peso	Confezione
Code	Size	Weight	Packing
	M	Kg/um	N°
D28Z620	6x20	0,013	100
D28Z630	6x30	0,016	100
D28Z640	6x40	0,016	100
D28Z650	6x50	0,019	100
D28Z660	6x60	0,021	100

V28/15T bolt

V28/15T bolt produced in steel grade 8.8, galvanized according to UNI ISO2081 European 2002/95 Rohs

Special demand:
stainless steel A2 and A4
T bolt with nut included

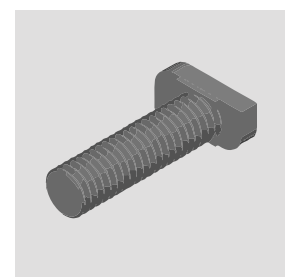

Accessories

V28/15 M 8 classe 8.8			
Codice	Misura	Peso	Confezione
Code	Size	Weight	Packing
	M	Kg/um	N°
D28Z830	8x30	0,021	100
D28Z840	8x40	0,025	100
D28Z850	8x50	0,028	100
D28Z860	8x60	0,032	100
D28Z880	8x80	0,037	100
D38Z8100	8x100	0,045	100

V28/15 M 10 classe 8.8			
Codice	Misura	Peso	Confezione
Code	Size	Weight	Packing
	M	Kg/um	N°
D28Z1020			
D28Z1030	10x30	0,032	100
D28Z1040	10x40	0,038	100
D28Z1050	10x50	0,043	100
D28Z1060	10x60	0,049	100
D28Z1080	10x80	0,058	100
D28Z10100	10x100	0,069	100

Carico rottura KN / Brocken load			
V28/15	M6	M8	M10
classe 8.8	8,04	14,6	23,2

Coppia torcente Nm / Torque			
V28/15	M6	M8	M10
classe 4.6	3	8	15

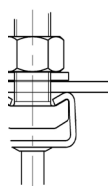

Viti V38/17

Vite V38/17 testa a martello prodotta in acciaio classe 8.8, finitura zincata secondo UNI ISO 2081 Europea 2002/95 Rohs

Produzioni su richiesta:
acciaio inox AISI 304 e 316
Vite fornita completa di dado

V38/17 M10 classe 8.8			
Codice	Misura	Peso	Confezione
Code	Size	Weight	Packing
	M	Kg/um	N°
D38Z1030	10x30	0,045	100
D38Z1040	10x40	0,048	100
D38Z1050	10x50	0,054	100
D38Z1060	10x60	0,058	100
D38Z1080	10x80	0,068	50
D38Z10100	10x100	0,079	50

V38/17 Screw

V38/17T bolt produced in steel grade 8.8, galvanized according to UNI ISO2081 European 2002/95 Rohs

Special demand:
stainless steel A2 and A4
T bolt with nut included

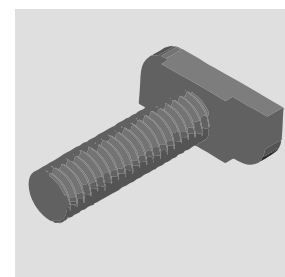

V38/17 M12 classe 8.8			
Codice	Misura	Peso	Confezione
Code	Size	Weight	Packing
	M	Kg/um	N°
D38Z1230	12x30	0,054	100
D38Z1240	12x40	0,064	50
D38Z1250	12x50	0,072	50
D38Z1260	12x60	0,080	50
D38Z1280	12x80	0,093	25
D38Z12100	12x100	0,110	25

Carico rottura KN / Brocken load		
V38/17	M10	M12
classe 8.8	46,4	67,4

Coppia torcente Nm / Torque		
V38/17	M10	M12
classe 8.8	15	25

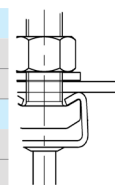

Viti V40/22

Vite V40/22 testa ad ancora prodotta in acciaio classe 4.6 e 8.8, finitura zincata secondo UNI ISO 2081 Europea 2002/95 Rohs

Produzioni su richiesta:
acciaio inox AISI 304 e 316.
Vite fornita completa di dado.

V40/22 T Bolt

V40/22T bolt produced in steel grade 4.6 and 8.8, galvanized according to UNI ISO2081 European 2002/95 Rohs

Special demand:
stainless steel A2 and A4.
Screw with nut included.

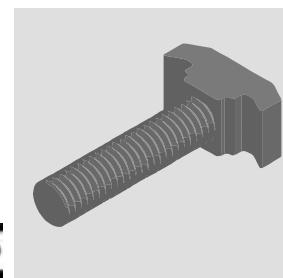

V40/22 M12 classe 4.6			
Codice	Misura	Peso	Confezione
Code	Size	Weight	Packing
	M	Kg/um	N°
D4Z1230	12x30	0,062	400
D4Z1240	12x40	0,077	300
D4Z1250	12x50	0,082	300
D4Z1260	12x60	0,087	250
D4Z1270	12x70	0,092	200
D4Z12100	12x100	0,121	150
D4Z12150	12x150	0,16	100

V40/22 M14 classe 4.6			
Codice	Misura	Peso	Confezione
Code	Size	Weight	Packing
	M	Kg/um	N°
D4Z1430	14x30	0,09	400
D4Z1440	14x40	0,101	300
D4Z1450	14x50	0,11	300
D4Z1460	14x60	0,121	250
D4Z1480	14x80	0,137	200
D4Z14100	14x100	0,155	150
D4Z14120	14x120	0,177	150
D4Z14150	14x150	0,199	100

V40/22 M16 classe 4.6			
Codice	Misura	Peso	Confezione
Code	Size	Weight	Packing
	M	Kg/um	N°
D4Z1630	16x30	0,111	400
D4Z1640	16x40	0,12	200
D4Z1650	16x50	0,132	200
D4Z1660	16x60	0,143	150
D4Z1680	16x80	0,163	150
D4Z16100	16x100	0,198	150
D4Z16110	16x110	0,209	150
D4Z16120	16x120	0,235	150
D4Z16150	16x150	0,254	100

V40/22 M12 classe 8.8			
Codice	Misura	Peso	Conf.
Code	Size	Weight	Packing
	M	Kg/um	N°
D4Z1230-88	12x30	0,062	400
D4Z1240-88	12x40	0,077	300
D4Z1250-88	12x50	0,082	300
D4Z1260-88	12x60	0,087	250
D4Z1270-88	12x70	0,092	200
D4Z12100-88	12x100	0,121	150
D4Z12150-88	12x150	0,16	100

V40/22 M14 classe 8.8			
Codice	Misura	Peso	Conf.
Code	Size	Weight	Packing
	M	Kg/um	N°
D4Z1430-88	14x30	0,09	400
D4Z1440-88	14x40	0,101	300
D4Z1450-88	14x50	0,11	300
D4Z1460-88	14x60	0,121	250
D4Z1480-88	14x80	0,137	200
D4Z14100-88	14x100	0,155	150
D4Z14120-88	14x120	0,177	150
D4Z14150-88	14x150	0,199	100

V40/22 M16 classe 8.8			
Codice	Misura	Peso	Conf.
Code	Size	Weight	Packing
	M	Kg/um	N°
D4Z1630-88	16x30	0,111	400
D4Z1640-88	16x40	0,12	200
D4Z1650-88	16x50	0,132	200
D4Z1660-88	16x60	0,143	150
D4Z1680-88	16x80	0,163	150
D4Z16100-88	16x100	0,198	150
D4Z16110-88	16x110	0,209	150
D4Z16120-88	16x120	0,235	150
D4Z16150-88	16x150	0,254	100

Carico rottura KN / Brocken load				
V40/22	M10	M12	M14	M16
classe 4.6	23,2	33,7	46	62,8
classe 8.8	46,4	67,4	92	125,6
Coppia torcente Nm / Torque				
V40/22	M10	M12	M14	M16
classe 4.6	15	25	35	35
classe 8.8	15	25	35	45

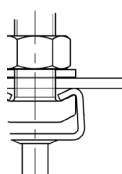

Profilo / channel GP40/221 - GP40/223

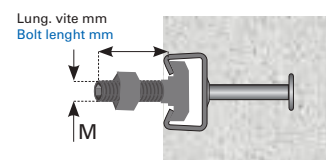

Vite V50/300

Vite V50/300 testa ad ancora prodotta in acciaio classe 8.8, finitura zincata secondo UNI ISO 2081 Europea 2002/95 Rohs

Produzioni su richiesta: inox AISI 304 e 316.

Vite fornita completa di dado.

V50/300 M16 classe 8.8			
Codice	Misura	Peso	Conf.
Code	Size	Weight	Pack.
	M	Kg/um	N°
D54Z1640-88	16x40	0,120	400
D54Z1650-88	16x50	0,132	300
D54Z1660-88	16x60	0,143	300
D54Z1670-88	16x70	0,153	250
D54Z16100-88	16x100	0,198	200
D54Z16120-88	16x120	0,219	150
D54Z16150-88	16x150	0,254	100

V50/300 T bolt

V50/300T bolt produced in steel grade 8.8, galvanized according to UNI ISO2081 European 2002/95 Rohs

Special demand: stainless steel A2 and A4.

T bolt with nut included.

V50/300 M20 classe 8.8			
Codice	Misura	Peso	Conf.
Code	Size	Weight	Pack.
	M	Kg/um	N°
D54Z2050-88	20x50	0,232	300
D54Z2060-88	20x60	0,243	300
D54Z2080-88	20x80	0,253	250
D54Z20100-88	20x100	0,298	200
D54Z20120-88	20x120	0,319	150
D54Z20150-88	20x150	0,354	100
D54Z20200-88	20x200	0,540	100

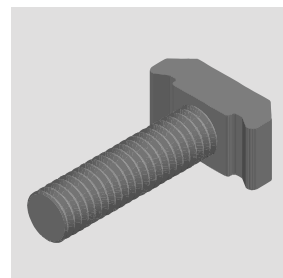

Profilo / channel GP50/30 e GP54/33

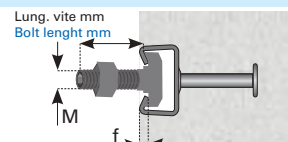

Carico rottura KN / Broken load

V50/300	M10	M12	M14	M16	M20
classe 4.6	23,2	33,7	46	62,8	98
classe 8.8	46,4	67,4	92	125,6	196

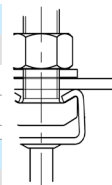

Coppia torcente Nm / Torque

V50/300	M10	M12	M14	M16	M20
classe 4.6	15	25	35	60	100
classe 8.8	15	25	35	60	120

H-bolt

H-bolt è l'accessorio per HGP Smart Anchor, è una barra filettata con testa a esagono esterno, zincato elettrolitico con estremità con colla blu antisvitamento.

Il dado H presente nel profilo non consente l'uscita di H-bolt all'interno del canale.

H-bolt

The H-bolt is an accessory for HGP Smart Anchor. It is a threaded bar with external hexagon head, electrolytic zinc plated, with blue anti-loosening glued end. The H-nut in the channel prevents the H-bolt entering the channel.

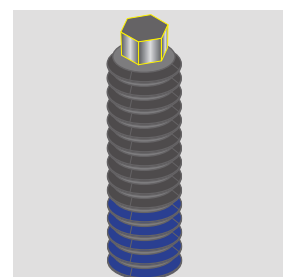

Profilo / channel HGP

H-bolt M16 classe 8.8			
Codice	Misura	Peso	Conf.
Code	Size	Weight	Pack.
	M	Kg/um	N°
HGPZ16	16x60	0,1128	150
HGPZ1670	16x70	0,1258	100
HGPZ1680	16x80	0,1386	100

Su richiesta possono essere fornite viterie con lunghezze diverse da quelle indicate in tabella

T bolts with different lengths than those specified in the table are available on demand

Vite VM3

Vite VM3 testa a martello prodotta in acciaio classe 4.6, finitura zincata secondo UNI ISO 2081 Europea 2002/95 Rohs.

Produzioni su richiesta: inox AISI 304 e 316.

Vite fornita completa di dado.

VM3 M12 classe 4.6

Codice	Misura	Peso	Confezione
Code	Size	Weight	Packing
	M	Kg/um	N°
D3Z1230	12x30	0,067	400
D3Z1240	12x40	0,072	300
D3Z1250	12x50	0,079	300
D3Z1260	12x60	0,087	250
D3Z1270	12x70	0,092	200
D3Z12100	12x100	0,101	100
D3Z12150	12x150	0,152	100

VM3 T bolt

VM3 T bolt produced in steel grade 4.6, galvanized according to UNI ISO2081 European 2002/95 Rohs.

Special demand:
stainless steel A2 and A4.
T bolt with nut included.

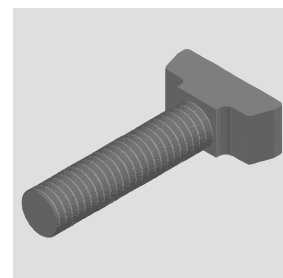

Profilo / channel GP1 - GL1

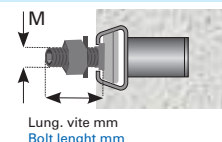

Carico rottura KN / Broken load	
VM3	M12
classe 4.6	33,7
classe 8.8	67,4

Coppia torcente Nm / Torque	
VM3	M12
classe 4.6	25
classe 8.8	25

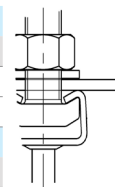

Su richiesta possono essere fornite viterie con lunghezze diverse da quelle indicate in tabella

T bolts with different lengths than those specified in the table are available on demand

Vite VM4

Vite VM4 testa ad ancora prodotta in acciaio classe 5.6, finitura zincata secondo UNI ISO 2081 Europea 2002/95 Rohs

Produzioni su richiesta:

inox AISI 304 e 316

Viti fornite complete di dado e rondella piana, ma non preassemblate.

VM4 T bolt

VM4 T bolt produced in steel grade 5.6, galvanized according to UNI ISO2081 European 2002/95 Rohs

Special demand:

stainless steel A2 and A4

T bolt with nut and plain washer included, but not preassembled.

Vite VM4 T bolt						
Codice Code	Filetto Thread	Zincatura Galvanized		Profilo Channel	Peso Weight	Confezione Packing
	M	A caldo H.D.G.	Elettrolitica Electrolytic	UnigiunTO	Kg/100	N°
DPV4E0840	M 8x40		•	K1-K2-K82	0,380	200
DPV4E1030	M 10x30	•	•	K1-K2-K82		200
DPV4E1240	M12x40		•	K1-K2-K82		100

Vite LFVTM T bolt					
Zincatura elettrolitica Electrolytic galvanized	Filetto Thread	Profilo Channel	Peso Weight	Confezione Packing	
	M	UnigiunTO	Kg/100	N°	
LFVTM0830	M 8x30	K30-K32	0,261	100	
LFVTM1030	M 10x30	K30-K32	0,316	100	

Dado VM4 Nut					
Zincatura elettrolitica Electrolytic galvanized	Filetto Thread	Molla Spring	Profilo Channel	Peso Weight	Confezione Packing
	M		UnigiunTO	Kg/100	N°
LVM4-06	M 6	senza	K1-K2-K82	2,75	100
LVM4-08	M 8	without	K1-K2-K82	2,75	100
LVM4-10	M 10	senza	K1-K2-K82	3,60	100
LVM4-12	M 12	without	K1-K2-K82	4,10	100
LVM4S06	M 6	corta	K2	2,84	100
LVM4S08	M 8	short	K2	2,84	100
LVM4S10	M 10	corta	K2	3,50	100
LVM4S12	M 12	short	K2	3,50	100
LVM4L06	M 6	lunga	K1	2,94	100
LVM4L08	M 8	long	K1	2,94	100
LVM4L10	M 10	lunga	K1	3,64	100
LVM4L12	M 12	long	K1	4,24	100

Prove di Trazione / Tensile test				
Dado Nut	Carico Amm. Trazione Friction Adm. Load	Rottura Failure	Coppia di chiusura Clamping Torque	Carico Inizio Scorrimento Begin Frictional Load
	kN	kN	Nm	kN
VM4-M6	3,62	>10,85	15	0,66
VM4-M8	4,93	>14,80	28	3,00
VM4-M10	7,03	>21,10	56	4,50
VM4-M12	9,07	>27,20	65	5,70

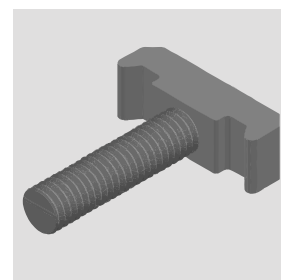

Profilo / channel GPK2 - K1Z

Lung. vite mm
Bolt length mm

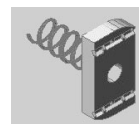
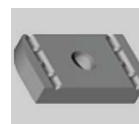
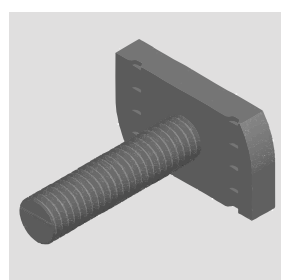
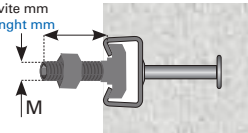

Installazioni:
- idrauliche
- elettriche

Installazioni:
- hydraulic
- electrical

Ancoraggi con profilo GL1

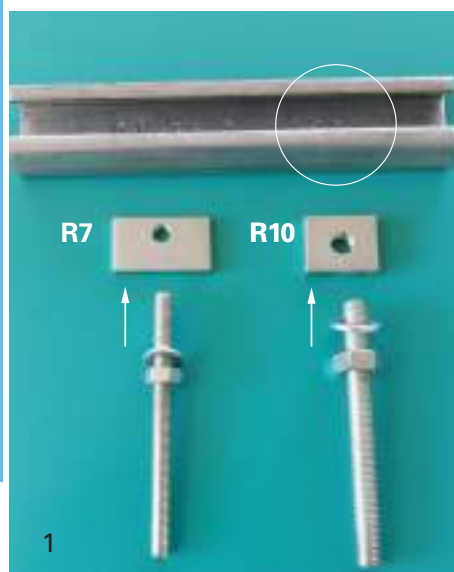

Componenti R7 M8 e R10 M10
 R7 M8 and R10 M10 components

Anchoring with GL1 channel



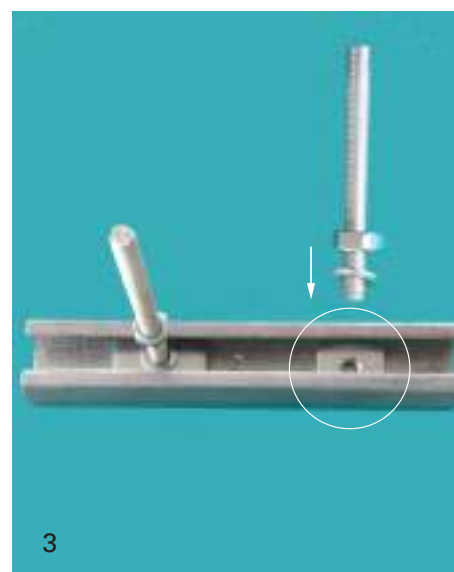

R7 assemblata - R10 nel profilo
 R7 assembled - R10 into the channel

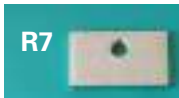
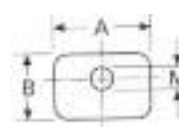

R7 installata - R10 avvitare
 R7 installed - R10 to screw

Ancoraggi con profilo di ancoraggio GL1 / Anchoring system with GL1 channel

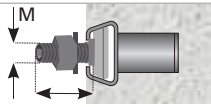
				GL1	
R7 - M8	Rondella Piana M8x24 Dado M8 Barra filettata M8	Assemblare tutti gli elementi	Inserire il fissaggio pre-montato nel profilo GL1 posizionarlo e avvitare la barra filettata M8 fino a toccare l'interno del profilo GL1.	Ancoraggio Rapido Portata 4 kN	
	Plain washer M8x24 Nut M8 Threaded rod M8	Assemble all the elements	Insert the pre-assembled mounting in GL1 anchor channel position it and screw the threaded rod up to touch the inside of GL1 channel.	Quick anchor Load 4 kN	
R10 - M10	Rondella Piana M10x30 Barra filettata M10 Dado M10	Inserire la piastrina R10 nel profilo GL1	Assemblare il dado e la rondella sulla barra filettata M10 ed avvitare nella piastrina posta all'interno del profilo Avvertenza : la piastrina R10 deve trovarsi nel profilo prima di essere avvitata sulla barra M10.	Ancoraggio Rapido Portata 4 kN	
	Washer plain M10x30 Threaded rod M10 Nut M10	Insert the R10 plate in the GL1 anchor channel	Assemble the nut and washer on the M10 threaded rod and screw at the plates, inserted inside the profile. Attention: The R10 plate must be in the profile, before it's screwed into the M10 bar.	Quick anchor Load 4 kN	
VM3 M12	Vite VM3 Dado M12	Assemblare tutti gli elementi	Inserire il fissaggio nel profilo GL1 (pagina viti)	Ancoraggio Rapido Portata 5,2 kN	
	Bolt VM3 Nut M12	Assemble all the elements	Insert the mounting in GL1 anchor channel see (page T bolt)	Quick anchor Load 5,2 kN	Lung. vite mm Bolt length mm

Piastrina R42 plate

Piastrina filettata per pendinature con barra filettata.

These are small threaded plates for attaching hangers and systems.

Per GP40/221 e GP40/223

For GP40/221 and GP40/223

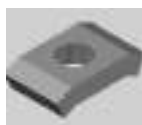

Piastrina R42 Plate				
Codice / Code	A	B	M	S
R42Z-08	29	15	8	5
R42Z-10	29	18	10	6
R42Z-12	30	18	12	6

Piastrina R7 plate

Piastrina filettata per pendinature con barra filettata.

These are small threaded plates for attaching hangers and systems.

Per GL1

For GL1

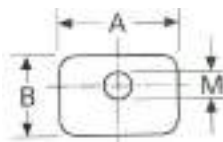
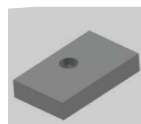

Piastrina R7 Plate				
Codice / Code	A	B	M	S
R7Z-06	40	24	6	4
R7Z-08	40	24	8	4
R7I-06	40	24	6	4
R7I-08	40	24	8	4

Piastrina R510 plate

Piastrina filettata per pendinature con barra filettata.

These are small threaded plates for attaching hangers and systems.

Per GP50/30

For GP50/30



Piastrina R510 Plate				
Codice / Code	A	B	M	S
R510Z-10	43	25	10	4
R510I-08	43	25	8	5
R510I-10	43	25	10	5

Dado Nut



UNI 5588 - DIN 934
zincato / galvanised

Dado / Nut			
Codice Code	Misura Size	Peso Weight	Confezione Packing
	M	Kg/um	N°
ADZ12	12	0,017	250
ADZ14	14	0,025	250
ADZ16	16	0,033	250
ADZ20	20	0,050	250

Rondella piana Plain washer



Diametri ottimali per montaggio sul profilo
Optimum diameters for the installation on the anchor channel
zincato / galvanised

Rondella piana / Plain washer			
Codice Code	Misura Size	Peso Weight	Confezione Packing
	M	Kg/um	N°
APZ12	12	0,008	250
APZ14	14	0,011	250
APZ16	16	0,014	250
APZ20	20	0,023	250

Rondella grower Spring washer

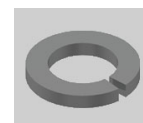

UNI 1751 special
sezione quadra / square section

zincato / galvanised

Rondella grower / Spring washer			
Codice Code	Misura Size	Peso Weight	Confezione Packing
	M	Kg/um	N°
AGZ12	12	0,005	250
AGZ14	14	0,007	250
AGZ16	16	0,010	250
AGZ20	20	0,015	250

Dado autobloccante Self locking hex nut



zincato
galvanised

Dado autobloccante / Self locking hex nut			
Codice Code	Misura Size	Peso Weight	Conf. Packing
	M	Kg/um	N°
ADZA12-7473	12	0,019	250
ADZA14-7473	14	0,027	250
ADZA16-7473	16	0,035	250
ADZA20-7473	20	0,043	250

Manicotto Coupling



zincato
galvanised

Manicotto / Coupling			
Codice Code	Misura Size	Peso Weight	Confezione Packing
	M	Kg/um	N°
141	12	0,084	250
142	14	0,109	200
143	16	0,150	100
144	20	0,194	50

Barra filettata Threaded rod

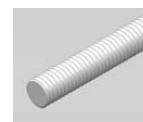

zincato
galvanised

Barra filettata / Treaded rod		
Codice Code	Misura Size	Lunghezza Length
	M	cm
BZ08	8	100
BZ10	10	100
BZ12	12	100

Piastra PX46

Piastra zincata forgiata a caldo con rinforzo della testa ad ancora e zigrinatura antiscorrimento. La piastra PX deve essere impiegata con la contropiastra PY.

La contropiastra PY è zigrinata e dotata di un dentello che assicura il corretto posizionamento sulla piastra PX durante il montaggio.

PX46 plate

Hot forged galvanized plate with reinforcement of the shaped head and no-sleeve tothing. PX plate must be used with PY counter plate.

PY counter plate is also toothed and has a tooth to assure right positioning on the PX plate, during installation.

Piastra PX46 Plate

Codice zincato Galvanised code	A	B	C	D	S	Peso Weight	Confezione Packing
	mm	mm	mm	mm	mm	Kg.	N°
PZPX4612	120	37	56	17	8	0,23	100
PZPX4614	140	39	78	17	8	0,24	50
PZPX4617	170	55	88	17	8	0,29	50
PZPX4621	210	63	120	17	8	0,34	50
PZPX4627	270	123	120	17	8	0,41	25
PZPY2	38	38	-	13	8	0,09	250
PZPY6	38	38	-	17	8	0,09	100

Profilo / channel rail GP40/223 GP40/221

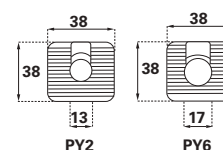
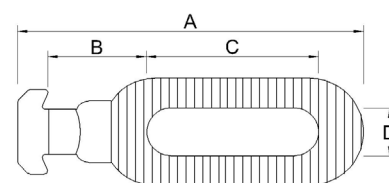
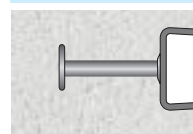

Piastra PX54

PX54 plate

Piastra PX54 Plate

Codice zincato Galvanised c.	A	B	C	D	S	Peso Weight	Confezione Packing
	mm	mm	mm	mm	mm	Kg.	N°
PZPX5414	140	33	75	21	8	0,31	50
PZPX5416	160	40	88	21	8	0,36	50
PZPX5421	210	58	120	21	8	0,45	50
PZPY5	45	45	-	17	8	0,12	100
PZPY20	45	45	-	21	8	0,09	250

Profilo / channel rail GP50/30 GP54/33

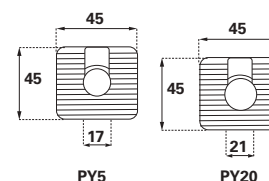
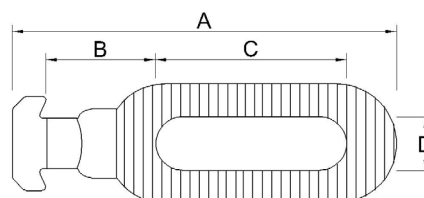
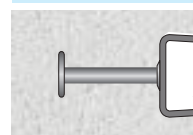

Piastra PXB612

Piastra zincata forgiata a caldo con l'estremità filettata per l'inserimento del bullone, zigrinatura antiscivolo. La piastra PXB612 deve essere impiegata con la contropiastra PY.

La contropiastra PY è zigrinata e dotata di un dentello che assicura il corretto posizionamento sulla piastra PXB612 durante il montaggio.

PXB612 Plate

Hot forged galvanized plate with reinforcement of the shaped head and anti slip toothing. PXB612 plate must be used together with PY counter plate.

PY counter plate is also toothed and has a tooth to assure the right positioning on the PX plate during the installation.

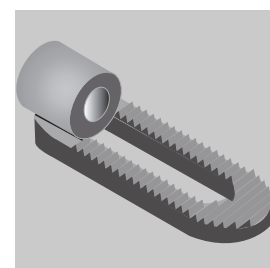

Piastra PXB612 Plate								
Codice zincato Galvanised code	A	B	C	M	D	S	Peso Weight	Confezione Packing
	mm	mm	mm	mm	mm	mm	Kg.	N°
PZPXB614	120	30	74	14	17	8	0,24	100
PZPXB616	120	30	74	16	17	8	0,23	100
PZPY2	38	38	-	12	12	8	0,09	250
PZPY6	38	38	-	16	16	8	0,09	100

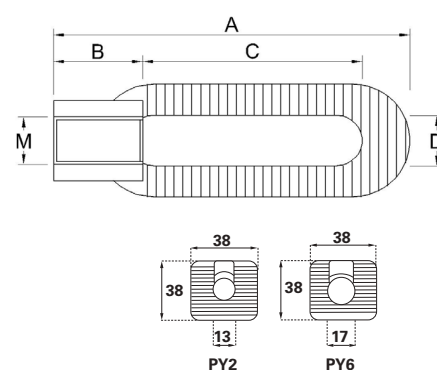

Contropiastra PY

Piastra forgiata a caldo con dentello per il corretto accoppiamento con l'asola zigrinata.

PY plate

Toothed hot forged plate for right coupling with toothed hole.

Contropiastra PY Plate								
Elettro zincato Electrolytic galv.	Zincato a caldo Hot dip galv.	A	B	D	S	Peso Weight	Confezione Packing	
		mm	mm	mm	mm	Kg.	N°	
PZPY2	PCPY2	38	38	13	8	0,09	250	
PZPY6	PCPY6	38	38	17	8	0,09	100	
PZPY5	PCPY5	45	45	17	8	1,12	100	
PZPY20	PCPY20	45	45	21	8	0,08	250	

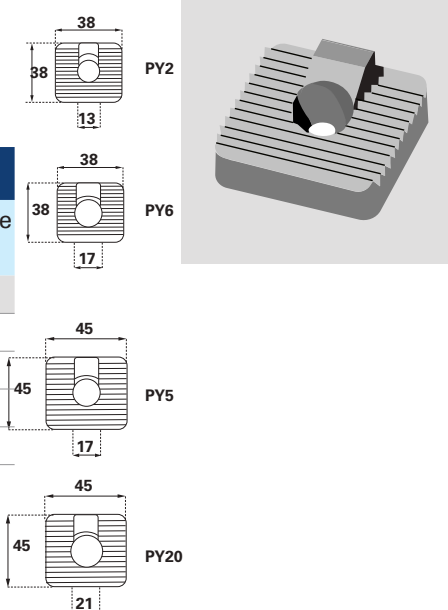

Ai fini di migliorare la qualità e le prestazioni dei prodotti GL Locatelli, ci riserviamo la facoltà di apportare modifiche senza alcun preavviso.

In the interests of improving the quality and performance of GL Locatelli products, we reserve the right to make specification changes without prior notice.

Piastra 20/05 Plate									
Codice zincato	L	A	B	C	M	E	S	F	Peso
Galvanised c.	mm	mm	mm	mm	mm	mm	mm		Weight
	mm	mm	mm	mm	mm	mm	mm		Kg.
20/05	60	80	150	80	17	35	8	●	0,96
20/05B	60	80	150	80	17	35	8	-	0,72
20/05A	60	80	200	80	17	35	8	●	1,06
20/05C	60	80	200	80	17	35	8	-	1,05

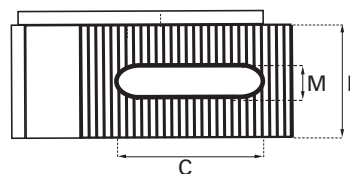
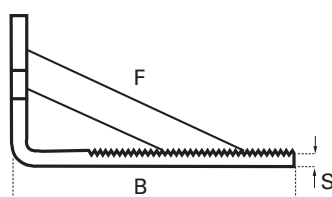
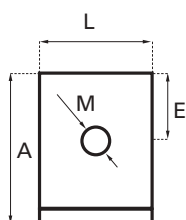
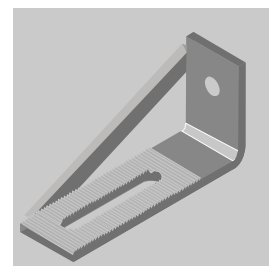

Piastra LDZ

Piastra zigrinata con asole in linea. La piastra prevede la zigrinatura su entrambe le asolature.

LDZ Plate

Galvanized plate with slots on the same axis. Plate is toothed on both slots.

Piastra LDZ Plate									
Codice zincato	L	A	B	C	M	E	S1	S2	Peso
Galvanised c.	mm	mm	mm	mm	mm	mm	mm	mm	Weight
	mm	mm	mm	mm	mm	mm	mm	mm	Kg.
PZLDZ	80	100	150	60/60	18	20	8	6	1,25
PZLDZL	80	150	150	90/90	18	20	8	6	1,46

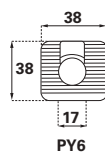
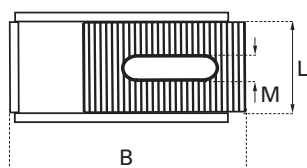
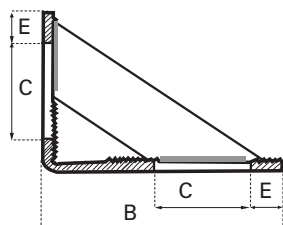
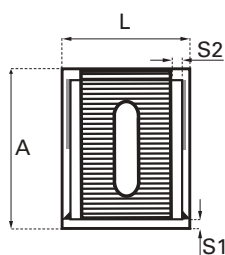
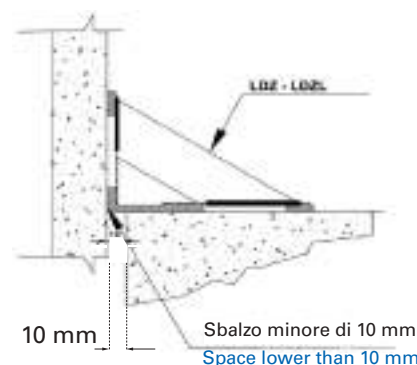

Portata 14 kN 14 kN load

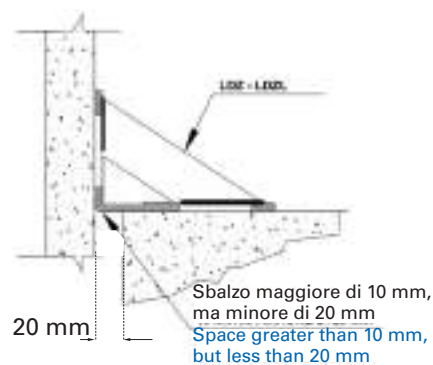

Portata 7 kN 7 kN load

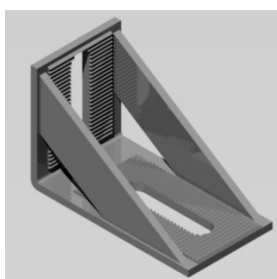

Piastra 05/01

Piastra zincata di collegamento tra strutture. La piastra 05/01 prevede la zigrinatura sul lato da 150 mm e l'asola posta ortogonalmente sul lato da 100 mm.

Plaque 05/01 plate

Galvanized plate connecting structures. The plate 05/01 includes a toothing on the 150 mm side and a slot positioned orthogonally on the 100 mm side.

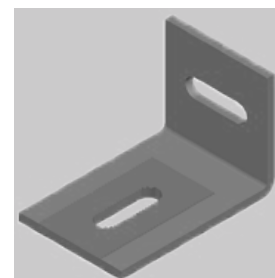

Accessories

Piastra 05/01 Plate								
Codice zincato Galvanised c. code	L	A	B	C	E	M	S	Peso Weight
	mm	mm	mm	mm	mm	mm	mm	Kg.
05/01	100	100	150	60/60	18/36	18	8	1,23

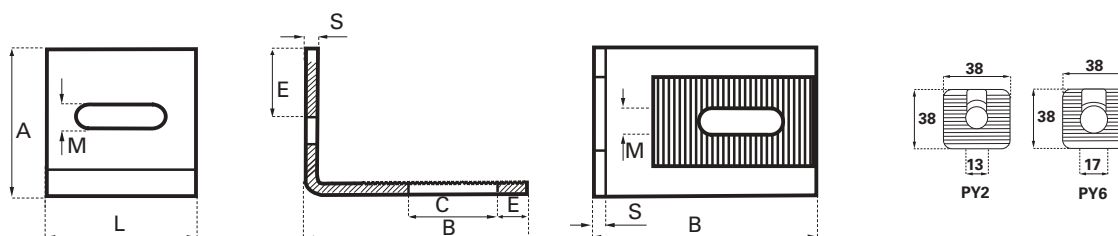

Piastra LD disassate

Piastra ad L con disassamento delle asole. La piastra viene realizzata nella versione destra o sinistra.

Misalignement LD plates

L plate with misalignement of the slots. The plate is made in the left or right version.

Piastra LD Plate											
Codice zincato Galvanised c. code	L	A	B	C1	E1	C2	E2	M	S	Descrizione Description	Peso Weight
	mm	mm	mm	mm	mm	mm	mm	mm	mm		Kg.
PZLD	100	85	100	50	15	75	18	14	6	Destra Right	0,80
PZLDSX	100	85	100	50	15	15	75	14	6	Sinistra Left	0,80

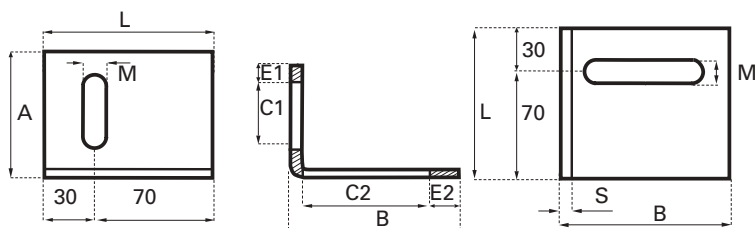

Piastra LD destra
LD right plate

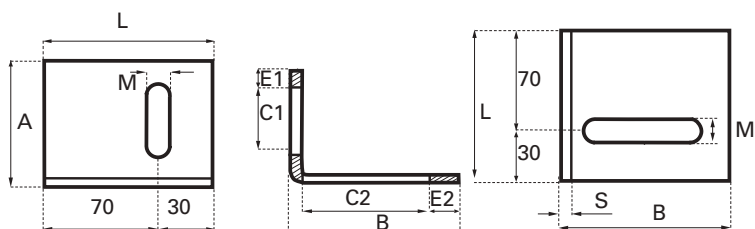
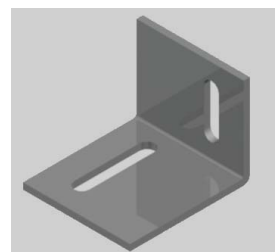

Piastra LD SX sinistra
LD SX left plate

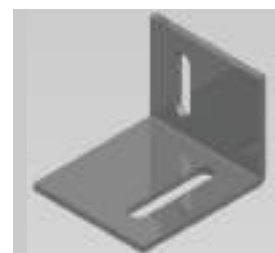

Antiscorrimento

Questa sezione presenta una serie di piastre dentate che agevolano la regolazione verticale durante l'installazione in cantiere.

Piastre per regolazione lungo l'asse dell'asola.
 La zigrinatura garantisce l'antiscorrimento del sistema a fissaggio avvenuto.

Anti-slip toothed

This section presents a series of plates to facilitate vertical adjustment during the installation on building site.

Plates for the adjustment along the axis of the slot.
 Toothing guarantees antislipping of system once the fixing is carried out.

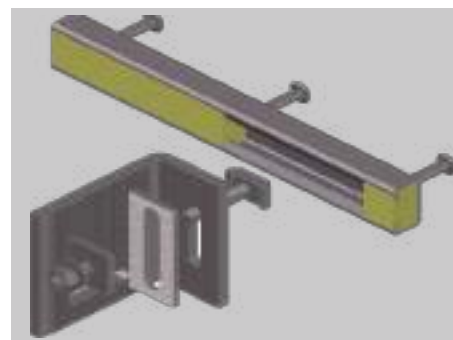

Piastra PNZ Plate								
Codice Code	Nero Black	F_{RD}	A	B	C	D	S	Peso Weight
		kN	mm	mm	mm	mm	mm	Kg.
PNZ1004565		32	45	100	85	17	6,5	0,15
PNZ80358		32	35	80	50	17	6,5	0,23

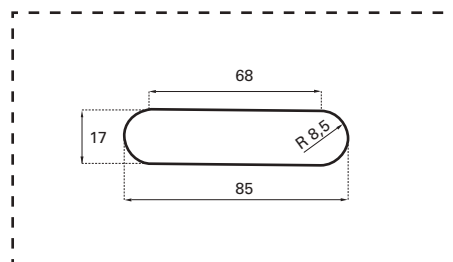
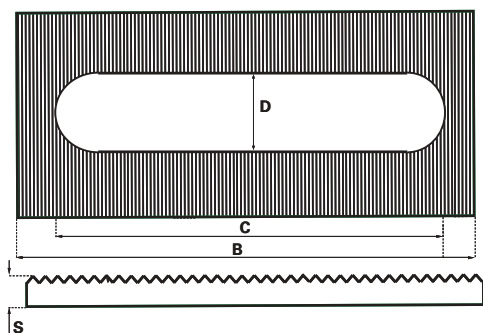

Dettaglio del supporto per piastra PNZ
 Support detail for PNZ plate

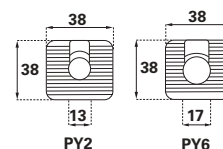

Piastra PIC

Piastra con colletto nella versione zincata elettrolitica e zincata a caldo con la funzione di trasformare una piastra liscia in piastra zigrinata idonea ad impedire lo scorrimento in direzione perpendicolare alla vite di fissaggio

PIC plate

Plate with collar electrolytic and hot dip galvanized with function to transform a flat plate in a toothed plate to prevent slip in perpendicular direction relative to fixing T bolt.

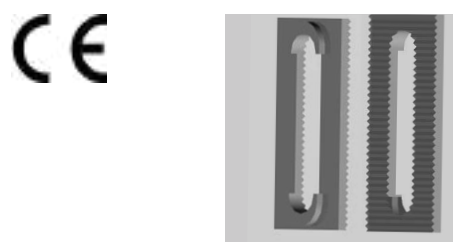

Piastra PICC2 Plate									
Zincato a caldo Hot dip Galv.	F_{RD}	A	B	C	D	E	F	S	Peso Weight
	kN	mm	mm	mm	mm	mm	mm	mm	Kg.
PICC2	22	45	100	85	17	97	22	6,5 + 4	0,16

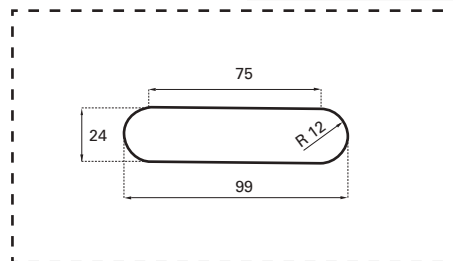

Dettaglio del supporto per piastra PICC2
 Support detail for PICC2 plate

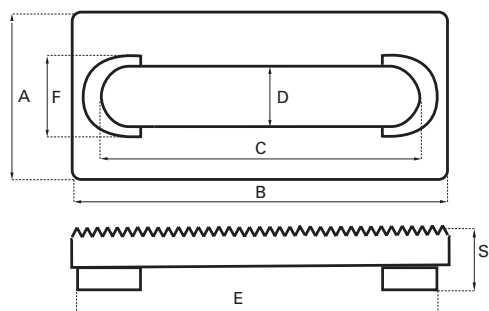
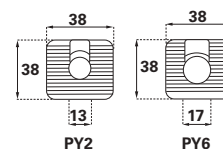

Piastra PICC2B Plate

Zincato a caldo Hot dip Galv.	F_{RD}	A	B	C	D	E	F	S	Peso Weight
	kN	mm	mm	mm	mm	mm	mm	mm	Kg.
PICC2B	22	50	80	60	22	72	27	6,5 + 4	0,150

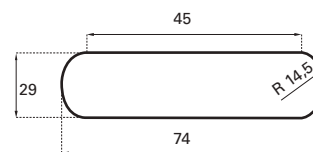
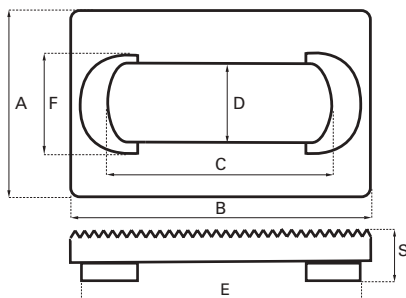
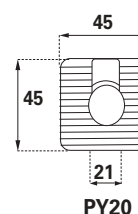
 Dettaglio del supporto per piastra PICC2B
 Support detail for PICC2B plate

Piastra PICC2C Plate

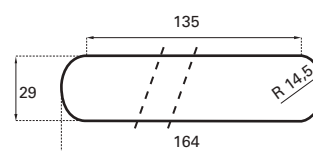
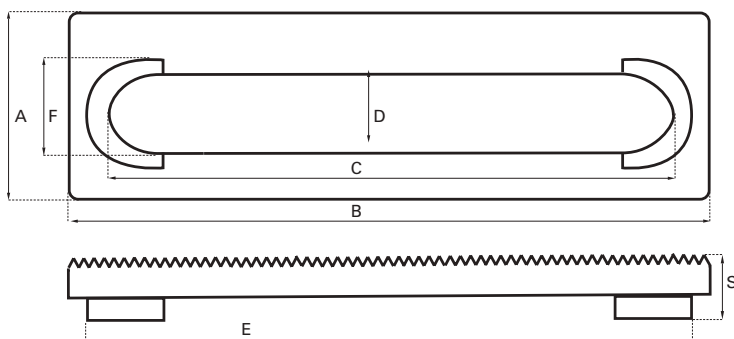
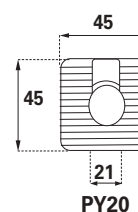
Zincato a caldo Hot dip Galv.	F_{RD}	A	B	C	D	E	F	S	Peso Weight
	kN	mm	mm	mm	mm	mm	mm	mm	Kg.
PICC2C	22	50	170	150	22	162	27	6,5 + 4	0,150

 Dettaglio del supporto per piastra PICC2C
 Support detail for PICC2C plate

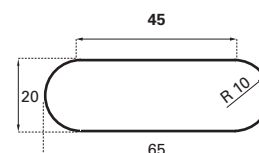
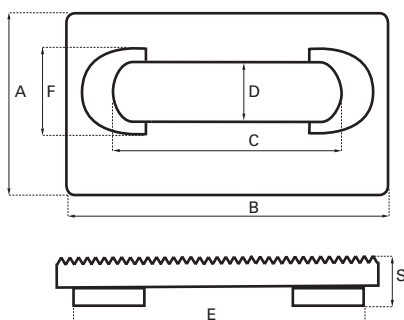
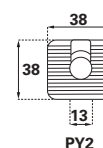
Piastra 13/04 Plate

Zincato a caldo Hot dip Galv.	F_{RD}	A	B	C	D	E	F	S	Peso Weight
	kN	mm	mm	mm	mm	mm	mm	mm	Kg.
13/04	17	45	70	50	13	63,5	18	6,5 + 4	0,125



 Dettaglio del supporto per piastra 13/04
 Support detail for 13/04 plate

Piastra 08/12

Piastra con 6 piedini zincata a caldo con la funzione di trasformare una piastra liscia in piastra zigrinata idonea ad impedire lo scorrimento in direzione perpendicolare alla vite di fissaggio.

08/12 plate

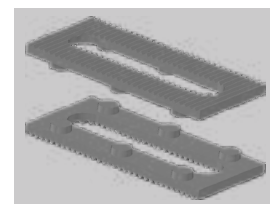
Hot dip galvanized 6 pins plate with function to transform a flat plate in a toothed plate to prevent slip in the perpendicular direction to the fixing T bolt.



Piastra 08/12 Plate								
Zincato a caldo Hot dip Galv.	+PY6 F_{RD} kN	+PY5 F_{RD} kN	A mm	B mm	C mm	D mm	S mm	Peso Weight Kg.
08/12A	32	44	45	100	85	17	6,5 + 4	0,16

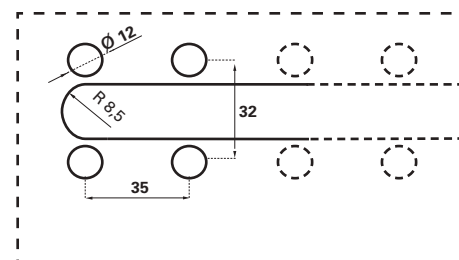

Dettaglio del supporto per 08/12A
Support detail for 08/12A

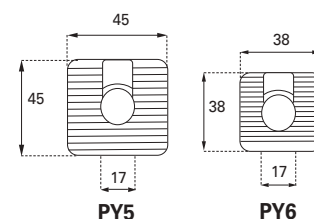
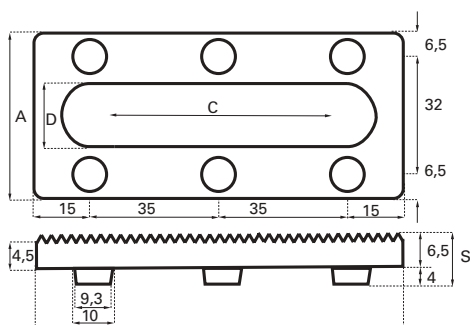

Piastra 13/03

Piastra con 4 piedini zincata a caldo con la funzione di trasformare una piastra liscia in piastra zigrinata idonea ad impedire lo scorrimento in direzione perpendicolare alla vite di fissaggio.

13/03 plate

Hot dip galvanized 4 pins plate with function to transform a flat plate in toothed plate to prevent slip in perpendicular direction relative to fixing T bolt.

Piastra 13/03 Plate							
Zincato a caldo Hot dip Galv.	F_{RD} kN	A mm	B mm	C mm	D mm	S mm	Peso Weight Kg.
13/03	17	45	70	50	13	6,5 + 4	0,12

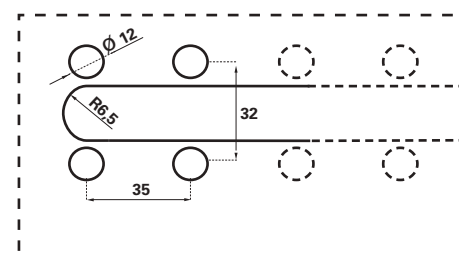

Dettaglio del supporto 13/03
Support detail for 13/03

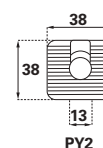
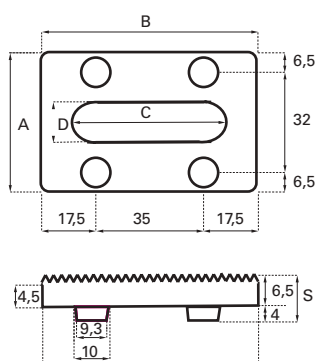

TQUADRO sistema per pannelli sandwich

Tquadro è un sistema per la produzione di pannelli prefabbricati in calcestruzzo a taglio termico o sandwich. Il pannello prodotto con Tquadro è completato dal certificato di conformità alla norma UNI EN ISO 6946 per la prestazione energetica della dichiarazione di trasmittanza. La produzione di pannelli ad alte prestazioni energetiche consente la riduzione della dispersione termica dell'edificio a beneficio dei costi di gestione dell'immobile e dell'ambiente.

TQUADRO sandwich panels

Tquadro system produces thermal shear or sandwich concrete prefabricated panels. The panel produced with Tquadro is completed with a certificate of compliance with UNI EN ISO 6946 standard for the energy performance of the transmittance statement. The production of high-performance energy panels permits the reduction of the building thermal dispersion, for the benefit of management costs of the building and the environment .

Componenti di TQUADRO IT			
Codice	Descrizione	pezzi /scatola	peso/scatola
		N.	Kg
A70	70x70x165h mm tubo strutturale inox 304 - A2	12	8,20
A80	80x80x165h mm tubo strutturale inox 304 - A2	9	10,60
	<i>A70 e A80 lavorano come mensole per sostenere il peso della lastra esterna portata</i>		
AS	74x110x35H mm scatola assorbitore inox 304 - A2	12	3,20
	<i>La scatola AS è prescritta solo se necessaria. Assorbe le dilatazioni/contrazioni della lastra esterna</i>		
FF	255x100xx200H mm staffa principale inox 304 - A2	200	17,00
L	100x200H mm staffa inox 304 - A2	250	17,50
CA	800x10 mm distanziale plt con n. 2 L 100x200H	125	7,50
	<i>Produzione con rintracciabilità di lotti</i>		

TQUADRO components EN			
Code	Description	pieces/box	weight/box
		N.	Kg
A70	70x70x165h mm structural pipe stainless steel 304 - A2	12	8,20
A80	80x80x165h mm structural pipe stainless steel 304 - A2	9	10,60
	<i>A70 and A80 are brackets to support the weight of outer slab</i>		
AS	74x110x35H mm expansion box stainless steel 304 - A2	12	3,20
	<i>AS box is prescripte only if it is necessary. AS is the compansation of dilation/contraction of outer slab</i>		
FF	255x100xx200H mm main bracket stainless steel 304 - A2	200	17,00
L	100x200H mm bracket stainless steel 304 - A2	250	17,50
CA	800x10 mm plt spacer with n. 2 L 100x200H	125	7,50
	<i>Production with traciability lots</i>		

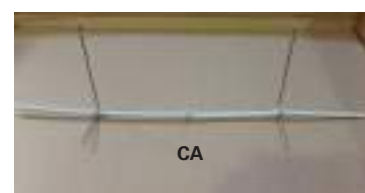

A70 + AS al centro del pannello

A70 + AS in the center of panel

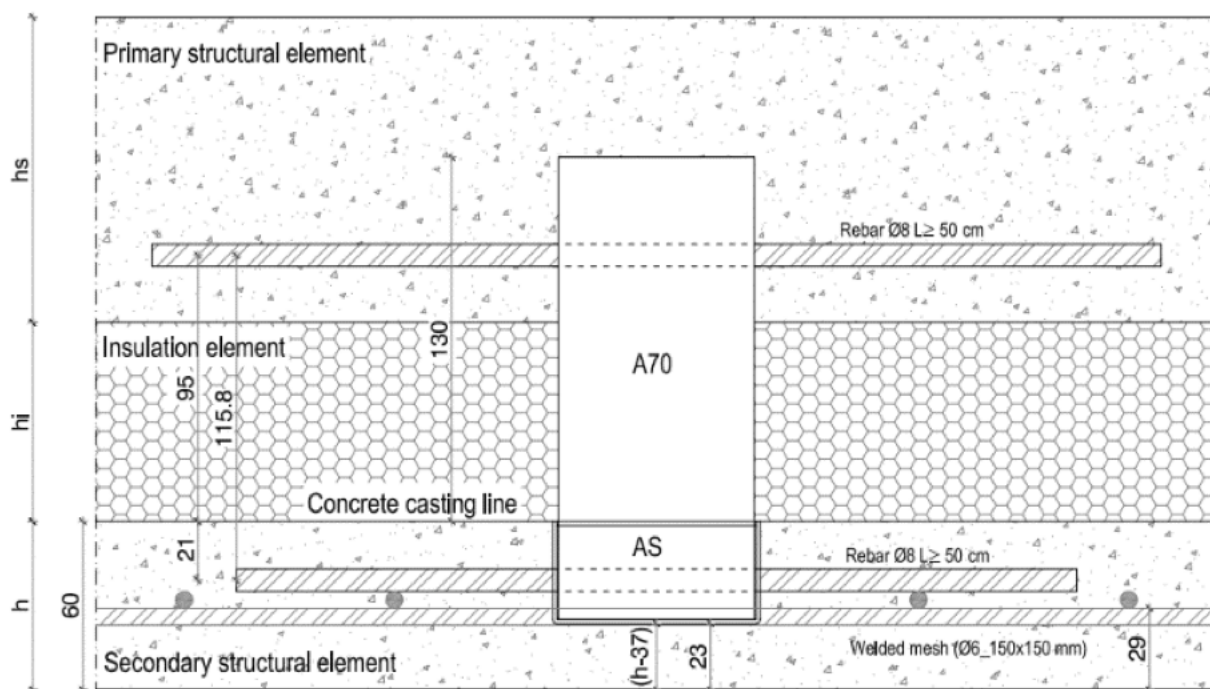

Spessore minimo della lastra esterna 60 mm. Nel disegno la sezione del pannello con la lastra esterna/portata prodotta a fondo cassero.

I ferri di armatura della scatola AS si appoggiano sulla rete elettrosaldata. Realizzato il getto di calcestruzzo, la scatola AS si presenta a filo del getto. Lo spessore dell'isolante e lo spessore della lastra interna/portante di calcestruzzo sono variabili. Tutti i componenti del sistema Tquadro hanno funzione strutturale e sono prodotti in acciaio inox 304 A2. L'acciaio inox assicura una bassa conducibilità, ottima duttilità ed elevata resistenza alla corrosione e alle basse temperature.

Quando il getto in calcestruzzo della prima lastra è ancora fresco, allestire il perimetro del cassero ponendo delle verghe di isolante da 100 mm e posizionare le staffe FF. La forma della FF permette di dare un ritmo alla posa; posata la prima FF si marca il calcestruzzo per due volte prima di posare la seconda staffa FF.

Minimum thickness of the external sheet 60 mm. The figure shows the panel section with the outside/supported sheet produced at the formwork bottom.

The reinforcing bars of the AS box lean on the welded mesh. Following the concrete casting, the AS box edges with the cast. The insulation thickness and the concrete inside/bearing sheet thickness vary. All the Tquadro system elements have a structural function and are made of 304 A2 stainless steel. Stainless steel guarantees a low conductivity, excellent ductility, and high resistance to corrosion and low temperatures.

When the concrete cast of the first sheet is still fresh, arrange the perimeter of the formwork by placing 100mm insulating rods and place the FF brackets. The FF shape permits to give a rhythm to the pose; when the first FF has been placed, you mark the concrete twice before you place the second FF bracket.

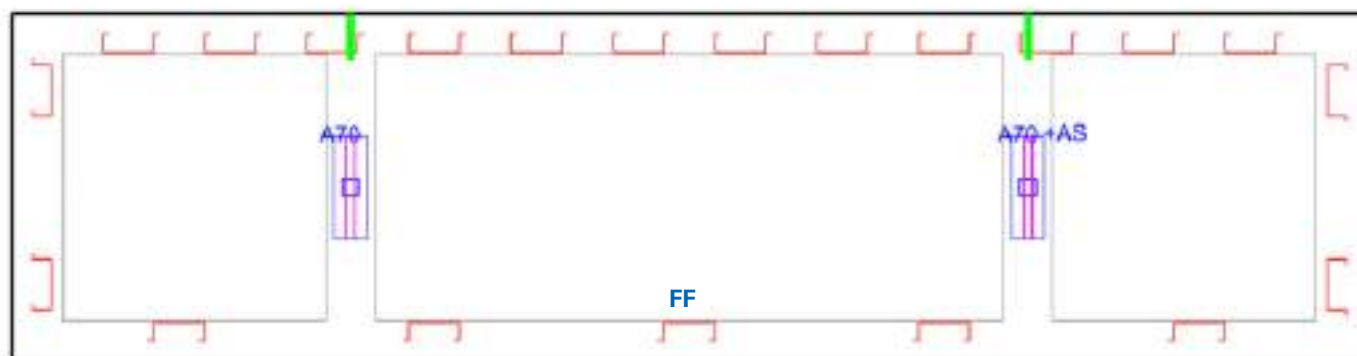

Schema della relazione di calcolo - pannello orizzontale
Calculation report scheme - horizontal panel

FF sul perimetro

Allestire il perimetro del cassero ponendo delle verghe di isolante da 100 mm e posizionare le FF quando il calcestruzzo è ancora fresco. La forma delle FF permette di dare un ritmo alla posa; posata la prima FF si marca il calcestruzzo per due volte prima di posare la seconda FF.

FF on perimeter

Arrange the perimeter of the formwork by placing 100mm insulating rods and place the FF when the concrete is still fresh. The FF shape permits to give a rhythm to the pose; when the first FF has been placed, you mark the concrete twice before you place the second FF bracket.

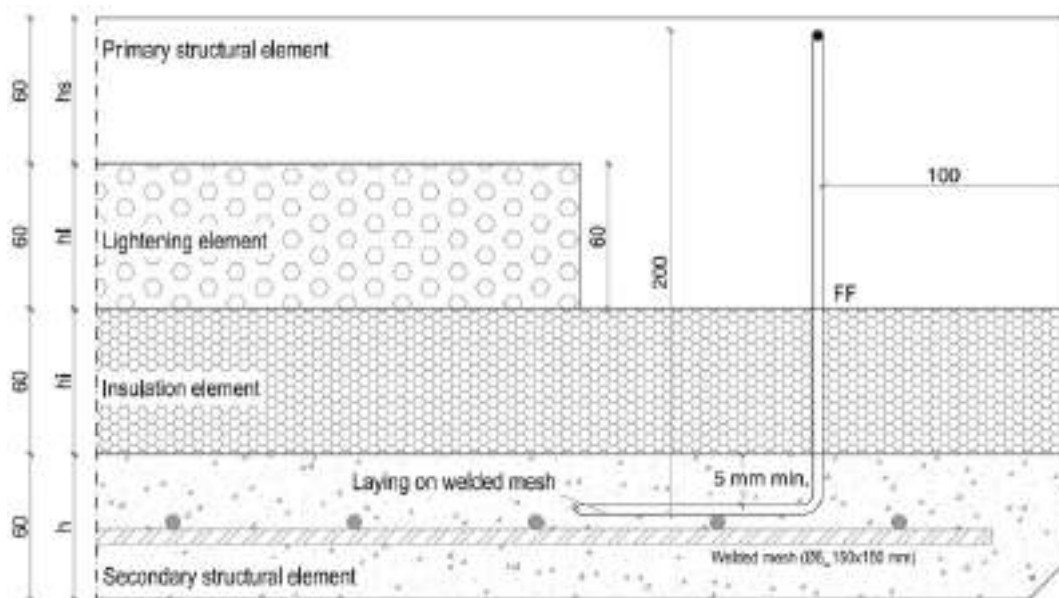

Fondo cassero
Formwork



1° getto - lastra esterna
1° jet - outer layer



Isolante posato
Insulation installed

Isolante

Qualora il pannello avesse un l'isolante di spessore maggiore di 60 mm è necessario ridurre lo spessore a 60 mm per una superficie di 150x600 mm attorno al Tubo strutturale A70 o A80

Insulation

Should the insulation thickness of the panel be higher than 60 mm, the thickness shall be reduced to 60 mm on a 150x600 mm surface around the A70 or A80 structural tube.

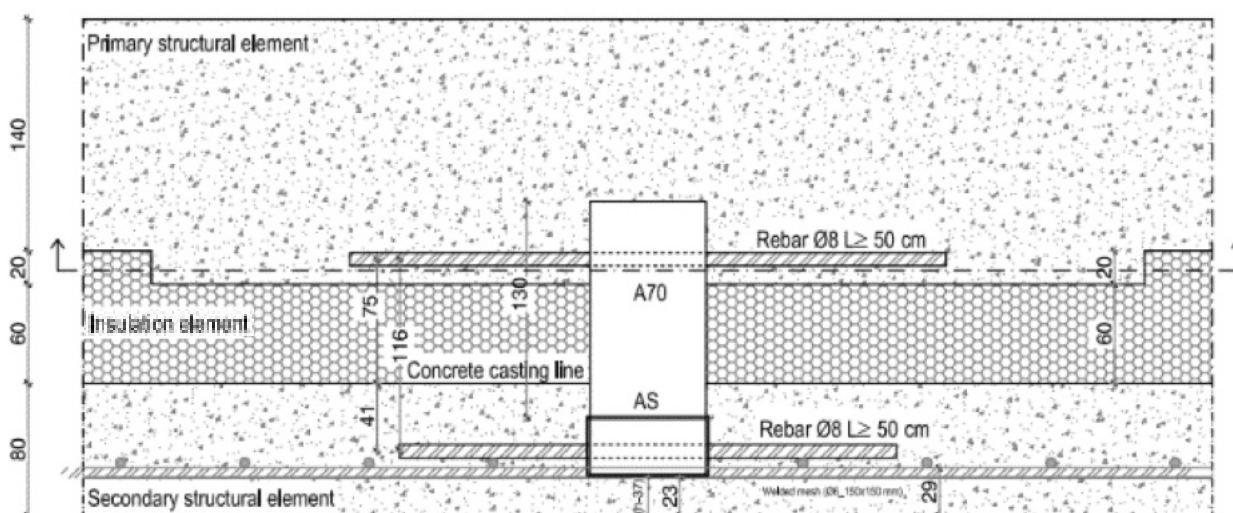
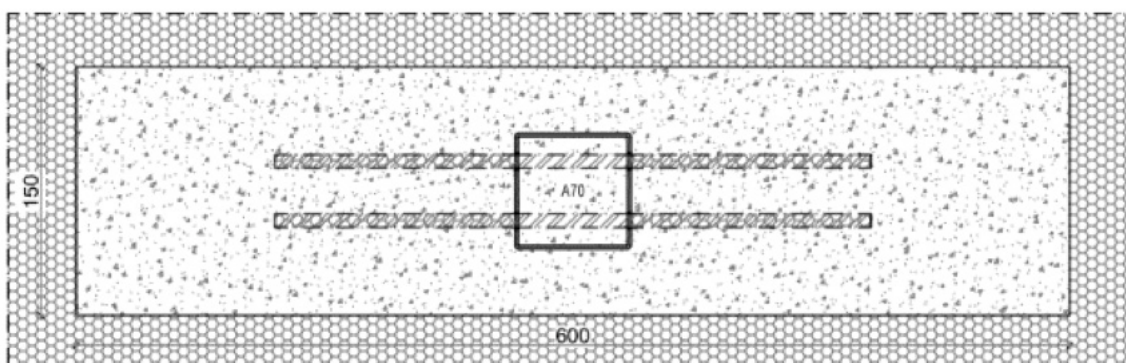

Per evitare la fessurazione della lastra esterna/portata, faccia a vista fondo cassero, si raccomanda l'aggiunta di fibre e di specifici additivi idraulici nella composizione del calcestruzzo.

L'estrazione del pannello dal cassero rappresenta la fase più delicata del processo di produzione. Il calcestruzzo della lastra portante deve essere maggiore di 15 N/mm².

La resistenza finale del calcestruzzo deve essere superiore a 25 N/mm²

In tutte le fasi di movimentazione e stoccaggio dei pannelli si raccomanda di non appoggiare a terra la superficie a vista esterna del pannello. La lastra esterna non deve mai reggere il peso dell'intero pannello e qualora venisse caricata potrebbe danneggiare l'integrità del manufatto. La lastra esterna potrebbe rompersi o causare pericolo per cose o persone nelle vicinanze.

I componenti necessari alla realizzazione di un pannello sono variabili ma sono sempre di poche tipologie.

Adding of fibres and specific hydraulic additives to the concrete composition is recommended to prevent cracking of the outside/supported sheet, side facing the formwork bottom.

Removing the panel from the formwork is the most delicate step in the production process. The bearing sheet concrete shall be more than 15 N/mm², The concrete final resistance shall be higher than 25 N/mm².

At all stages of panel handling and storage we recommend not to lay on the ground the panel outside visible surface. The outside sheet shall never support the weight of the entire panel and should it happen it could damage the integrity of the element. The outside sheet may break or cause danger to things or people nearby. The elements needed to make a panel vary, but they are always of a few types.

3 semplici componenti per realizzare il pannello con Tquadro

Nello schema raffigurato sotto sono presenti: n. 2 tubo A70 + n. 1 scatola assorbitore AS + n. 21 staffe FF.

Software Tquadro. Certificato della Trasmittanza, prestazione energetica del pannello

Il software che certifica la Trasmittanza e dichiara la prestazione energetica del pannello, compie un'analisi sulla struttura del pannello calcolando i carichi sugli appoggi, elenca i componenti per la produzione e lo schema di costruzione del pannello. Il software calcola i dati igrometrici e indica, se è necessario, l'uso della barriera al vapore. Nel software vanno indicate le misure del pannello, il tipo di pannello verticale/orizzontale, la stratigrafia, i materiali impiegati calcestruzzo/isolante.

Dal Software

From Software

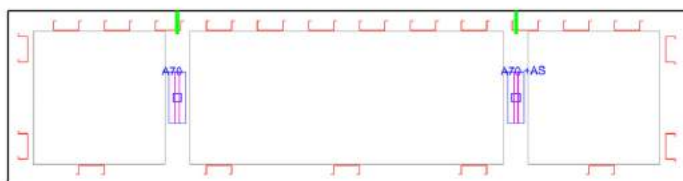

Elenco componenti:

A70 = n.2
AS = n. 1
FF = n. 21

Component list :

A70 = n.2
AS = n. 1
FF = n. 21

La certificazione avviene tramite l'uso del software il cui algoritmo è stato controllato e certificato dall'istituto Italiano ICMQ specializzato nel settore delle costruzioni, in conformità alle norme europee.

Tquadro è certificato da ICMQ n. 190/15/ISP Dagma s.r.l. Impiegando i componenti del sistema Tquadro, secondo le indicazioni prescritte dal software si producono pannelli conformi alla norma UNI EN ISO 6946:2018. La relazione di calcolo certifica la Trasmittanza ovvero la prestazione energetica del pannello.

Prova Sismica

Tquadro ha brillantemente superato le prove sismiche realizzate presso l'istituto italiano ITC-CNR svolte nel 2018. Le prove sono avvenute con pannelli verticali da 250x700 cm del peso di 7.500 Kg.

Dopo le prove la lastra esterna del pannello è risultata sempre integra.

<https://youtu.be/4nl-S4xpk8A>

Tquadro è un prodotto coperto da brevetto internazionale.

3 simple elements to make a panel with Tquadro

The drawing below shows: no. 2 A70 tubes + no. 1 AS absorber box + no. 21 FF brackets.

Tquadro software. Transmittance, panel energy performance certificate

The software that certifies the transmittance and states the panel energy performance makes an analysis of the panel structure by calculating the loads on the supports, lists the production elements and the panel construction scheme. The software calculates the hygrometric data and indicates the use of the steam barrier in case it is needed. The software requests you to type in panel size, panel type - vertical/horizontal -, stratigraphy, materials used - concrete/insulation.



In compliance with the European standards, certification is accomplished by using the software of which the algorithm has been controlled and certified by the Italian ICMQ Institute which specialises in the building sector. Tquadro is certified by ICMQ no. 190/15/ISP Dagma s.r.l. By using the Tquadro system components following the software prescriptions, panels complying with UNI EN ISO 6946:2018 standard are produced. The calculation report certifies the transmittance i.e. the panel energy performance

Seismic Test

Tquadro has brilliantly passed the seismic tests carried out at the Italian ITC-CNR Institute in 2018.

The tests were carried out on 250x700 cm vertical panels, weighing 7,500 kg.

After the tests, the panel outside sheet has always proved to be intact. <https://youtu.be/4nl-S4xpk8A>

Tquadro is covered by an international patent.

ASP **ASP mensola di supporto per pannelli orizzontali prefabbricati in calcestruzzo**

ASP bracket for precast concrete horizontal panel

Sistema per l'ancoraggio di pannelli prefabbricati in calcestruzzo alla struttura dell'edificio. Il sistema è costituito da due scatole di predisposizione da inserire nella colonna, elemento portante, e nel pannello elemento portato. L'ancoraggio consente le regolazioni in cantiere e diventa inaccessibile dopo il montaggio quando scompare alla vista. Idoneo all'impiego in zona sismica.

Anchorage system for concrete prefabricated panels and building structure. The system has two boxes that go inside the pillar, structural element, and in the panel, supported element. The anchorage system permits the adjustments on site and become inaccessible after assembly, when it disappears from view. Suitable for use in seismic areas.

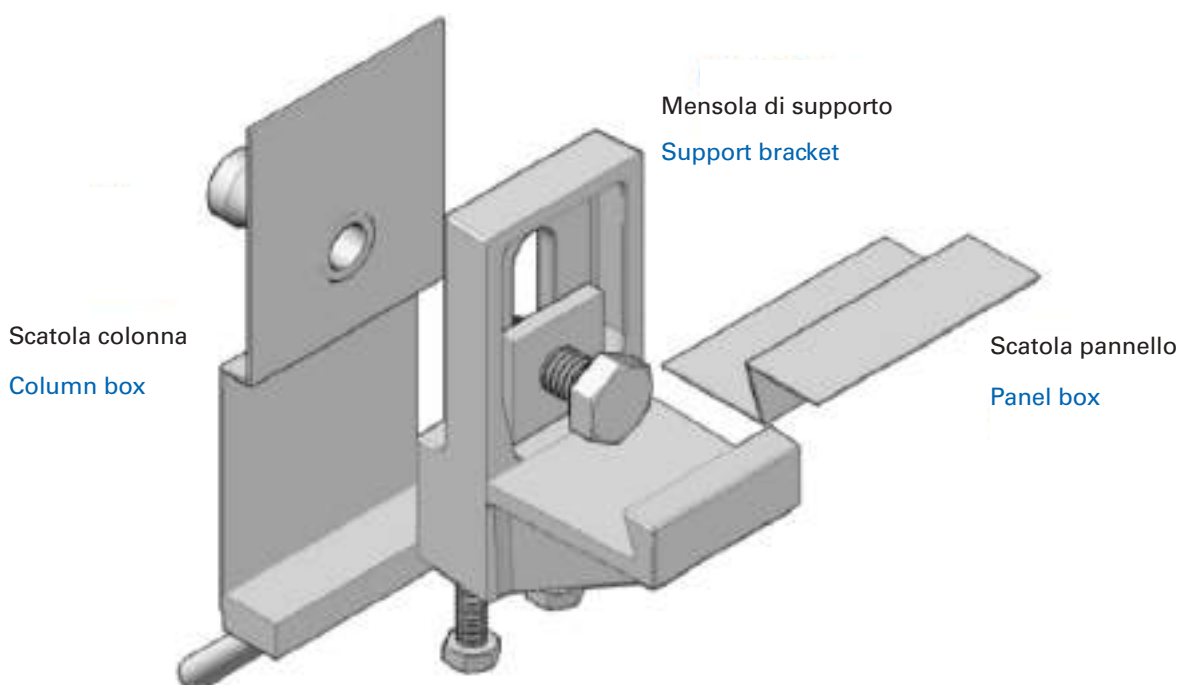

Prospetto **Prospect**

Sezione **Section**

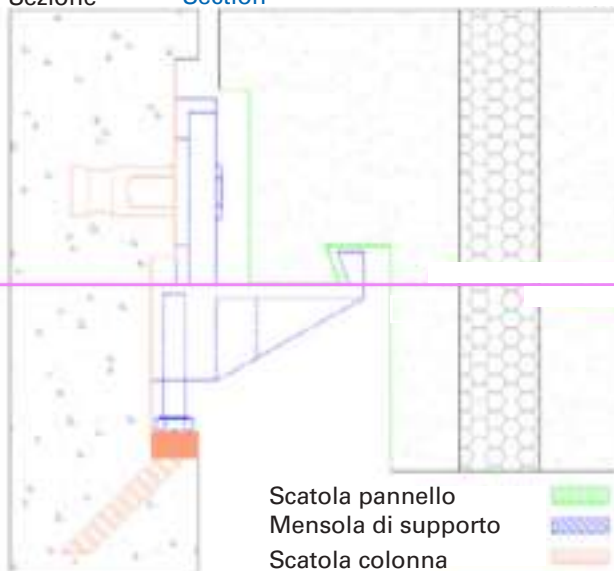
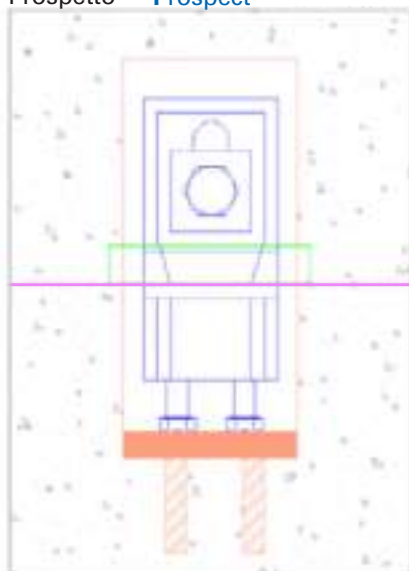

Piano "0" - di posizionamento della mensola
Plane "0" bracket positioning

Scatola pannello
Mensola di supporto
Scatola colonna

Panel box
Support bracket
Column box

Per l'impiego dell'ancoraggio sono necessarie queste fasi:

- Progettazione dei manufatti: colonna e pannello
- Inserire nel progetto della colonna la "scatola strutturale a)" facendo riferimento al Piano "0", inciso nel polistirolo di riempimento
- Inserire nel progetto del pannello, sul lato interno, in basso, a destra e a sinistra due "scatole pannello b)" facendo riferimento al piano di appoggio della scatola, Piano "0".
- Il Piano "0" è il riferimento per il posizionamento delle scatole all'interno dei casseri prima della produzione dei manufatti.
- La precisione nella collocazione delle scatole nella colonna e nel pannello permette di utilizzare le regolazioni nella fase di montaggio in cantiere.

The anchorage system requires the following steps:

- Design of elements – pillar and panel
- Insertion of the "a) structural box" in the pillar design, with reference to "0" Plane engraved in the filling polystyrene
- Insertion of two "b) panel boxes" in the panel design, inside, down, right and left, with reference to "0" Plane, the box support plane.
- "0" Plane is the reference for placing the boxes inside the formworks, before the production of the elements.
- Accuracy in placing the boxes in the pillar and in the panel permits the use of adjustments in the assembly stage on site.

a) Scatola colonna completa di riempimento

E' possibile fornire un elemento composto da due scatole accostate o unite da un traverso, definire la distanza L fra le due scatole

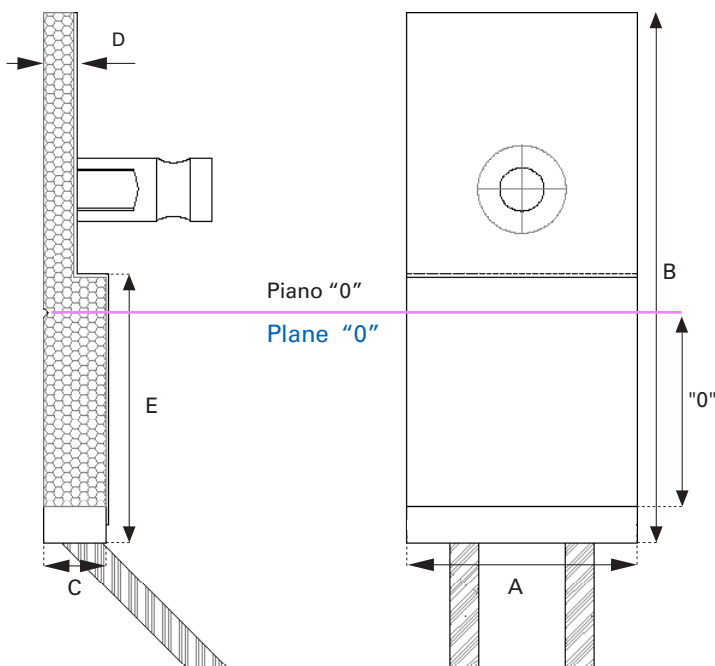

a) Pillar box complete with filling

You may be provided with an element made of two boxes juxtaposed or joined by a crossbar, and you may define the L distance between the two boxes.

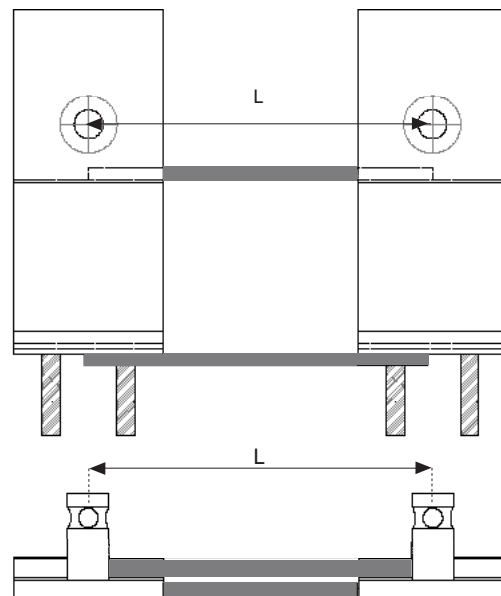

Scatola colonna - Column box								
Code	L	A	B	C	D	E	"0"	Weight
	mm	mm	mm	mm	mm	mm	mm	Kg.
6808C21		130	300	35	19	150	130	2,14
6808C21D	130	260	300	35	19	150	130	4,28
6808C21_L	-	130	300	35	19	150	130	-

b) Scatola pannello lunga L 150 mm, fornita completa di polistirolo.

E' possibile fornire la scatola con lunghezza maggiore.

b) Panel box length 150mm, delivered complete with polystyrene.

A longer box is available.

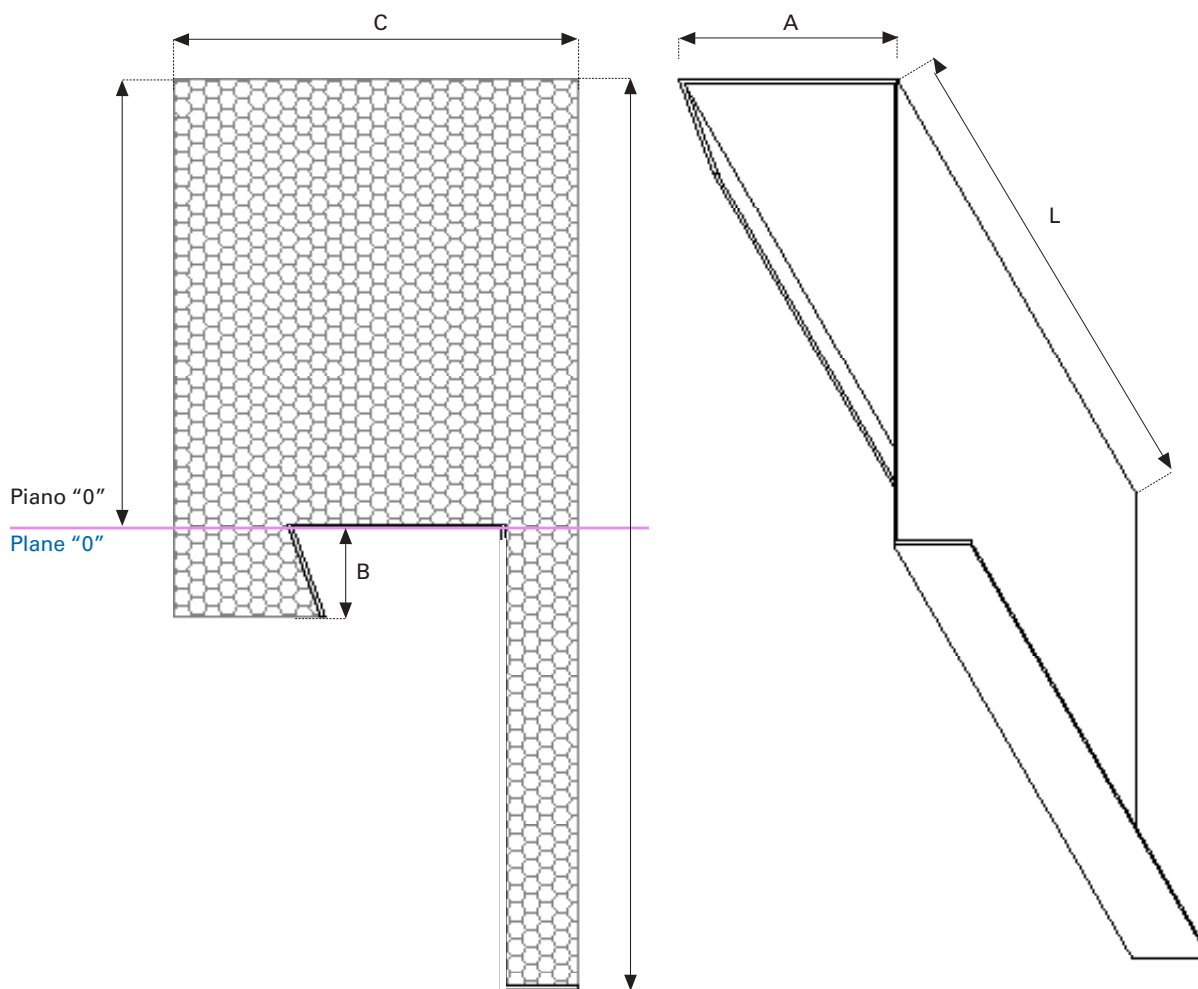

Scatola pannello - Panel box

Codice Code	L	A	B	C	D	"0"	Peso Weight
	mm	mm	mm	mm	mm	mm	Kg.
6808P21	150	69	30	127	285	140	0,23
6808P21_L	L	69	30	127	285	140	-

c) Mensola ed accessori

Quando le colonne raggiungono il cantiere, rimuovere il riempimento dall'interno delle scatole e inserire le mensole in acciaio. Preparare la mensola avvitando due viti TE M16x60 sotto al piano. Fissare la mensola c) all'interno della scatola a) usando la rondella quadrata e la vite M24x50. Prima di serrare M24, regolare la posizione del Piano "0".

c) Bracket and accessories

When the pillars arrive on site, remove the filling inside the boxes and insert the steel brackets. Set the bracket by screwing two TE M16x60 screws under the plane. Fix the c) bracket inside the a) box using the square washer and the M24x50 screw. Adjust "0" Plan position before tightening M24.

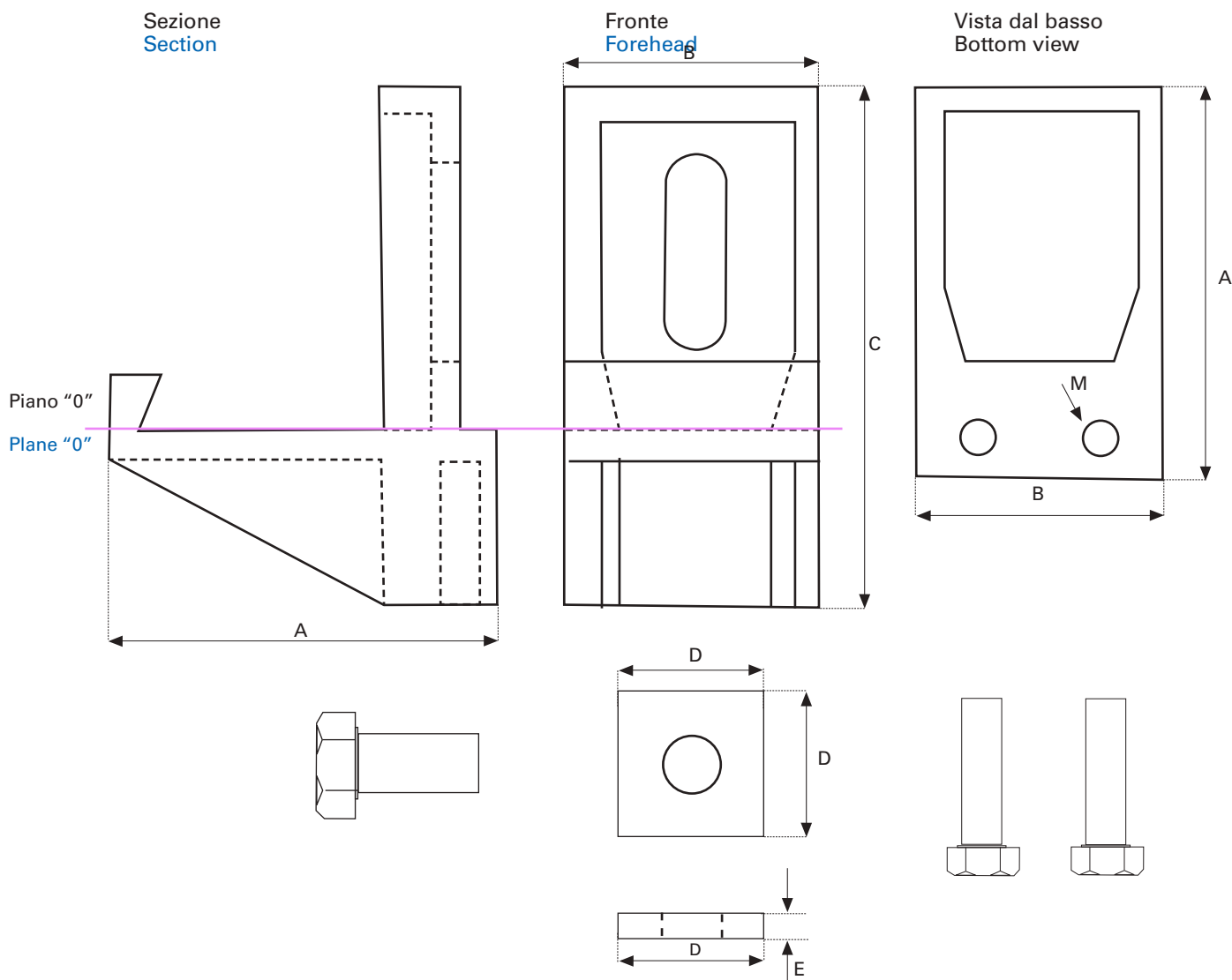

Mensola - Bracket

Codice Code	A	B	C	M	T1	T2	D	E	Peso Weight
	mm	mm	mm	mm	mm	mm	mm	mm	Kg.
6808M21	158	100	212	16	M16x60	M24x50	60	10	6,65

Perché è interessante la mensola ASP

La scatola colonna a) ha un ingombro ridotto, la doppia profondità si integra bene con le cerchiature dell'armatura d'acciaio della colonna. La scatola viene posizionata lungo la colonna e alla sua sommità.

La mensola c) è compatta e maneggevole.

I manufatti in calcestruzzo vengono estratti dai casseri e maneggiati in modo agevole perché non hanno sporgenze. Le regolazioni in cantiere offerte dalla mensola ASP sono interessanti perché prevedono tutte le direzioni di regolazione e offrono un'ampia escursione. La superficie di appoggio della mensola è ampia e assicura la stabilità del pannello. Una volta conclusa la regolazione della mensola e appoggiato il pannello sul piano, l'ancoraggio non è più accessibile. Il guscio di calcestruzzo che avvolge la mensola la protegge dalle manomissioni e dal fuoco.

Il dente a Z all'estremità del piano della mensola c) e della scatola pannello b) attribuiscono all'ancoraggio una funzione antisismica. In caso di sisma ondulatorio il pannello non può scivolare dalla mensola e in caso di sisma sussultorio con il pannello posto distante dalla colonna, posizione più gravosa, la Z impedisce il sollevarsi del pannello.

Because ASP bracket is interested

The a) pillar box is small sized, its double depth integrates well with the pillar steel reinforcement steel. The box is placed along the pillar and at its top.

The c) bracket is compact and handy.

The concrete elements are pulled out from the formworks and handled in an easy way because they have no ledges.

Adjustments on site permitted by the ASP bracket are interesting because they include all adjustment directions and offer a wide range. The bracket support surface is wide and ensures the panel stability. Once the bracket is adjusted and the panel is placed on the plane, the anchorage system is no longer accessible. The concrete shell that envelops the bracket protects it against tampering and fire.

The Z-tooth at the end of the c) bracket plane and the b) panel box give the anchoring an anti-seismic feature. In case of wave earthquake, the panel will not slip off the bracket and in case of shaking earthquake, being the panel far from the pillar – a more difficult position – the Z-tooth prevents the lifting of the panel.

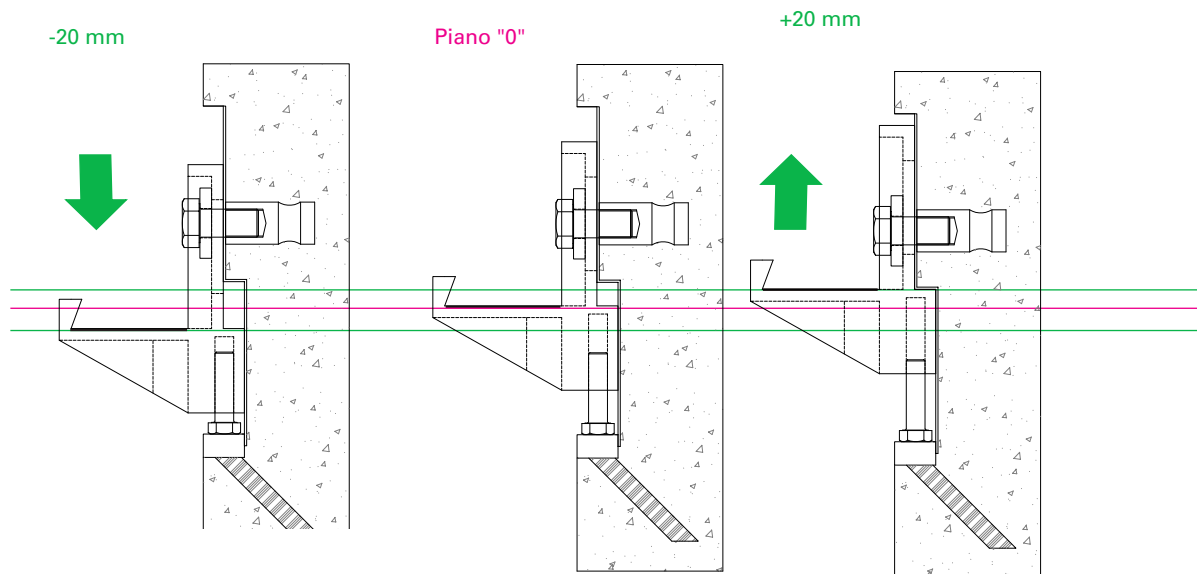

La scatola pannello da 150 mm è più lunga del piano della mensola di ± 25 mm. In caso di necessità si possono produrre scatole di diverse lunghezze

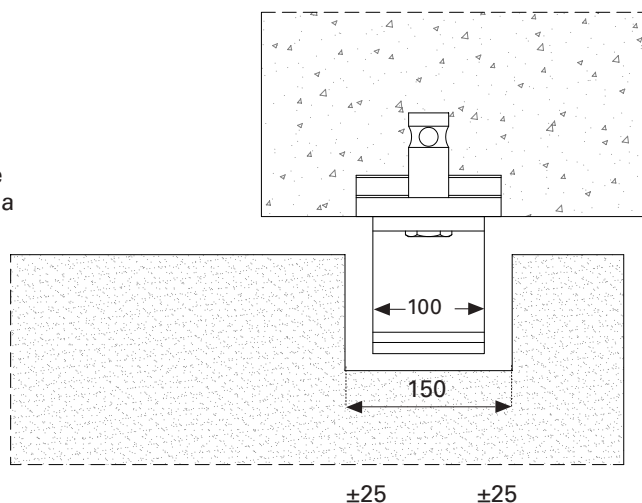

The 150 mm panel box is ± 25 mm longer than the bracket plane. Boxes of different lengths can be made if needed.

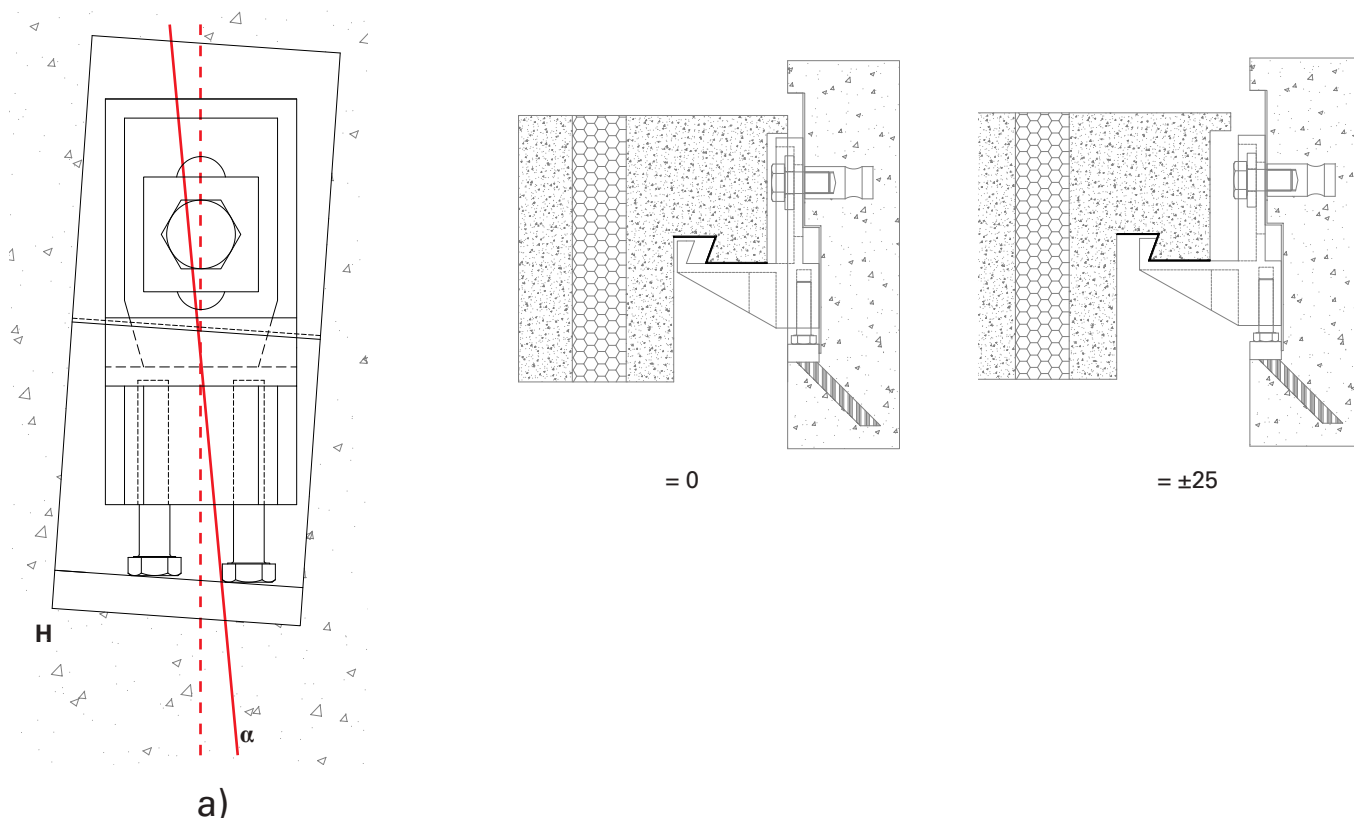

Nel caso in cui la scatola colonna a) non fosse in asse, il piano della mensola può essere corretto regolando le viti sottostanti fino ad un angolo di 4° ovvero H 10 mm.

Should the a) pillar box be off axis, the bracket plane can be corrected by adjusting the screws below up to a 4° angle i.e. 10mm H.

Prestazioni della mensola ASP

L'ancoraggio ASP vanta un'esperienza di oltre 40 anni nei cantieri di tutta Italia. Questo lungo periodo di utilizzo consente di affermare la buona prestazione all'azione sismica alla luce dei terremoti di L'Aquila Abruzzo 2009, Emilia Romagna 2013, Norcia Umbria 2016, tutti terremoti pari o superiori a 5,9 della scala Richter.

L'ancoraggio ASP è stato valutato con prove svolte presso i laboratori del Politecnico di Milano.

Le prestazioni si riferiscono all'uso di ASP su strutture con calcestruzzo $R_{ck} \geq 45$ Mpa e pannelli con $R_{ck} \geq 30$ con carichi combinati. E' disponibile il Manuale d'Uso.

Prestazioni della mensola ASP

ASP anchorage system boasts an experience of over 40 years on construction sites throughout Italy. This long period of use permits to state the good performance with respect to the seismic action in light of the earthquakes at L'Aquila (Abruzzo, 2009), Emilia-Romagna (2013), Norcia (Umbria, 2016), all equal to or greater than 5.9 degrees of the Richter scale.

ASP anchorage system has been validated by tests carried out at the laboratories of the Politecnico di Milano. Performances refer to the use of ASP on structures with $R_{ck} \geq 45$ Mpa concrete and $R_{ck} \geq 30$ panels, with combined loads. A user manual is available.

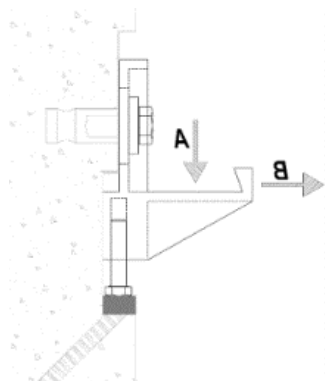

Prestazioni ASP Performance				
Codice Code	A	B	Pilastro/Trave Column/Beam	Pannello Panel
	kN	kN	Mpa	Mpa
6808M21	80	30	≥ 45	≥ 30

ASP Ancoraggi di trattenuta del pannello

Dopo che il pannello è in appoggio a terra, sulla trave di bordo, o in appoggio sulle mensole ASP deve essere fissato in sommità o sui lati per impedirne la caduta. Questi ancoraggi non possono portare il peso proprio del pannello né essere usati durante le manovre di movimentazione e regolazione del pannello in cantiere. La portata di ogni nodo dipende dalla collocazione e dai materiali impiegati, pertanto è necessaria la verifica secondo EN 1992-4 da parte del progettista delle strutture.

ASP boxes for upper anchoring for precast panel

After the panel is placed on the ground, on the edge girder or on the brackets, ASP system shall be fixed on top or on the sides to prevent it from falling. This anchorage system can neither support the panel weight nor be used during the handling manoeuvres or when adjusting the panel on site. The operating range of each joint depends on its position and the materials used, so it is necessary a check by the structural designer according to EN 1992-4 standard.

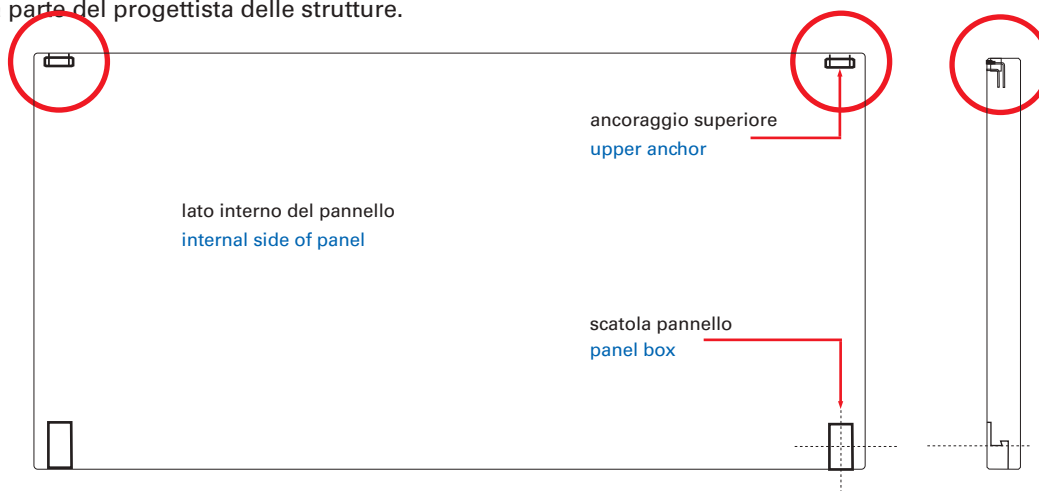

Disegno del pannello - dettaglio

Panel design - detail

ASP30

Profilo GP40/223 – ETA CE zincato sendzimir completo di polistirolo – montaggio del bullone dall'alto. Resistenza di calcolo 11,1 kN.

Accessori forniti a parte:
vite V40/22 M 16x40 con dado,
piastra PX4612+PY6.

ASP30

Anchor channel GP40/223 – CE marked, sendzimir galvanized and polystyrene – bolt installation from top. Maximum load 11,1 kN.

Accessories supplied separately:
screw V40/22 M16x40 with nut,
plate PX4612+PY6.

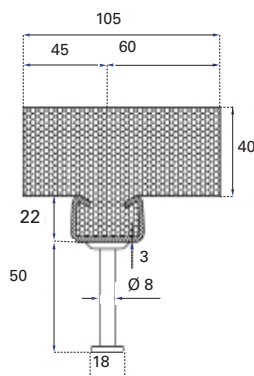
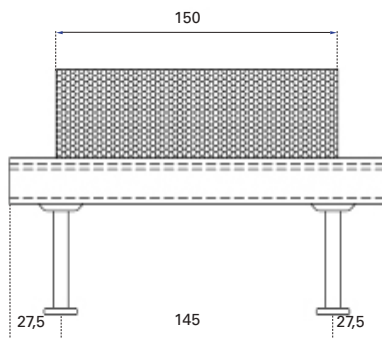

ASP40

Inserto ASP41 composto da tubolare con zanche, zincato elettrolitico, completo di polistirolo e piastra ASP43 montaggio laterale del bullone : laterale Resistenza di calcolo 10 kN.

Accessori forniti a parte: vite V40/22 M16x80 con rondella piana e dado

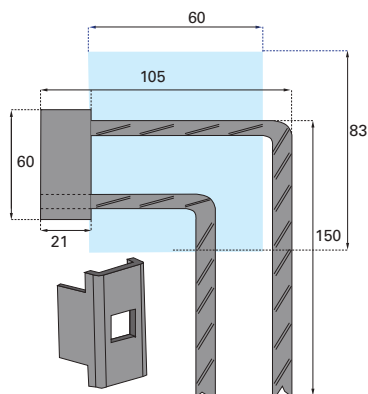

ASP40

Node made from ASP41 tubular profile with reinforcement rebars, zinc plated ASP43 and polystyrene – lateral installation of the bolt. Design load is 10 kN.

Accessories supplied separately: screw V40/22 M16x80 with flat washer and nut

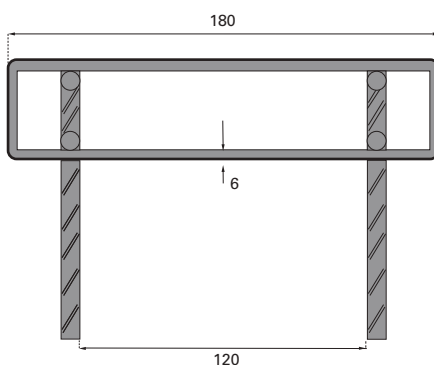

ASP

G2D

Inserto composto da scatola U con asola zigrinata e zanche, zincato elettrolitico, completo di polistirolo Montaggio del bullone: laterale Resistenza di calcolo 15 kN.

Accessori forniti a parte: vite V40/22 M16x100 con dado, rondella piana, piastra Py6

Il Polistirolo è fornito in imballi separati dall'ancoraggio in acciaio

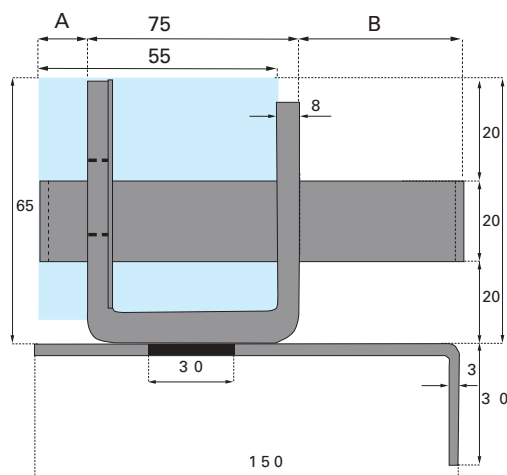

G2D

Node made of a U box with slot and rebar, galvanized with polystyrene - lateral installing of the bolt. Design load 15 kN (limit state design - LSD).

Accessories supplied separately: screw V40/22 M16x100 with flat washer and nut and PY6 plate.

Polystyrene is supplied in packaging detached from the steel anchoring

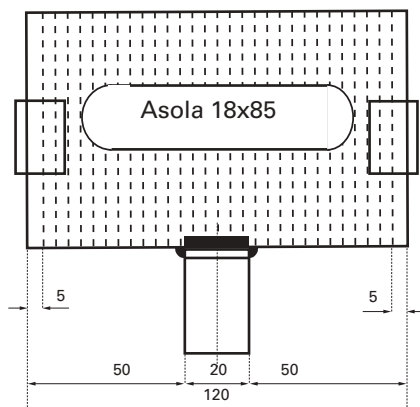

SRZ15

Insero composto da piatto zigrinato e zanche, zincato elettrolitico, completo di polistirolo.

Montaggio del bullone: laterale

Resistenza di calcolo 15 kN

Portata ammissibile 10 kN

Accessori forniti a parte: vite V40/22 M16x80 con dado, rondella piana, piastra Py6

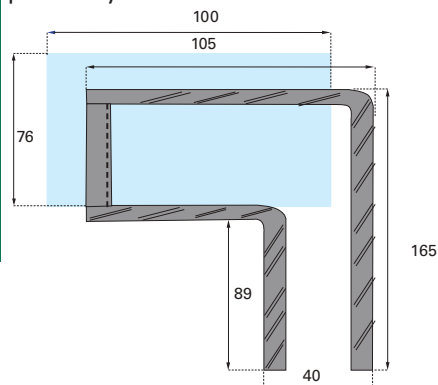

SRZ15

Node made of angular plate with slot, toothed with rebars, galvanized and with polystyrene.

Lateral installation of the bolt.

Calculation resistance 15 kN. (Limit State Design - LSD)

Permissible load 10 kN

Accessories supplied separately: screw V40/22 M16x80 with flat washer and nut and PY6 plate.

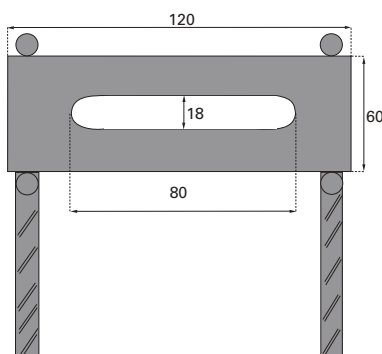

SR15-120

Insero composto da angolare zigrinato e zanche, zincato elettrolitico, completo di polistirolo

Montaggio del bullone: laterale

Resistenza di calcolo 15 kN

Portata ammissibile 10 kN

Accessori forniti a parte: vite V40/22 M16x80 con dado, rondella piana.

Il Polistirolo è fornito in imballi separati dall'ancoraggio in acciaio

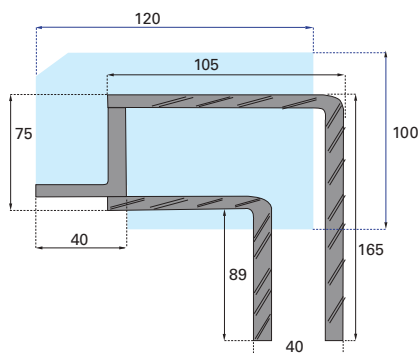

SR15-120

Node made of angular plate with slot, reinforcement with rebars, galvanized and with polystyrene.

Lateral installation of the bolt.

Calculation resistance 15 kN. (Limit State Design - LSD)

Permissible load 10 kN

Accessories supplied separately: screw V40/22 M16x80 with flat washer and nut.

Polystyrene is supplied in packaging detached from the steel anchoring

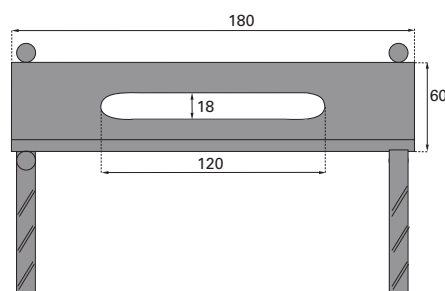

Chiodi a T

I chiodi a T sono forgiati da barre tonde e progettati per il carico utile da 13 kN a 450 kN. Il sistema è adatto per grandi elementi prefabbricati, quali lastre, travi, pannelli, tubi.

I chiodi **GL ANCHOR** da 25 kN a 200 kN **sono comprensivi di un coefficiente di sicurezza maggiorato del 50% $\gamma_{GL} = 1,5$ che garantisce la portata nominale uguale al peso sostenibile.**

Altri chiodi da 13 kN fino a 450 kN in acciaio ST52.3.

Nello stesso gruppo di carico, i chiodi a T sono disponibili con differenti lunghezze.

I chiodi a T più lunghi sono impiegati con l'uso di calcestruzzi a bassa resistenza o in prossimità dei bordi del manufatto.

Il carico viene trasmesso al calcestruzzo attraverso il gambo del chiodo fino al piede ancorante. Il maggior diametro del piede consente il trasferimento del carico al calcestruzzo con la formazione del cono.

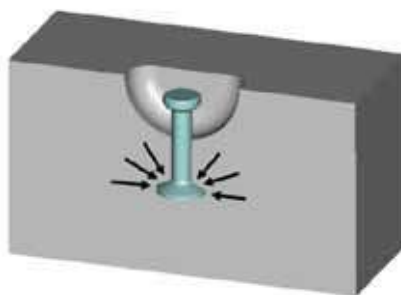

Gli ancoraggi devono essere fissati nel calcestruzzo utilizzando la forma. La forma mantiene il chiodo in posizione durante il getto di calcestruzzo.

La forma crea il vuoto attorno alla testa dell'ancora che corrisponde alla testa del sistema di sollevamento.

E' vietato usare chiodi e maniglioni di gruppo di carico diverso.

Quando il gancio si appoggia al calcestruzzo durante la trazione angolata, il carico orizzontale viene trasferito direttamente nel calcestruzzo.

T anchor

The T Anchors are forged from round steel and are designed to a load force in the range of 13 kN to 450 kN. Proper for large precast elements such as slabs, beams, panels pipes.

GL ANCHORS from 25 kN to 200 kN are made **with higher mechanical features, comprehensive of a 50% increased safety coefficient, i.e. $\gamma_{GL} = 1,5$. This factor guarantees the nominal flow equal to the sustainable weight.**

Other anchors from 13 kN to 450 kN are made from ST52.3 steel.

In the same load group, anchors are available with different lengths.

Longer anchors are installed for reduced edge spacing or for low concrete strengths.

The load on the anchor is transmitted to the concrete through the anchor foot.

The anchors must be fixed in the mould using recess formers. The recess former retains the anchor securely in position during the concrete pour.

The recess former creates a void around the anchor head which corresponds to the lifting system head (shackle).

The incorrect coupling of parts of different load groups is impossible. Another advantage is that the shackle rests against the concrete during angled pull and therefore the horizontal load is transferred into the concrete directly.

For this reason additional reinforcement is not required in large units.

In this walls, additional reinforcement is necessary for angled lift, to absorb the transverse pulling forces.

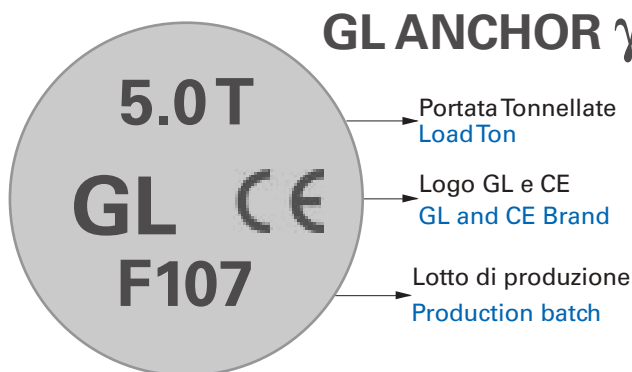

GL ANCHOR è in acciaio ad alte prestazioni
GL ANCHOR made in high resistance steel

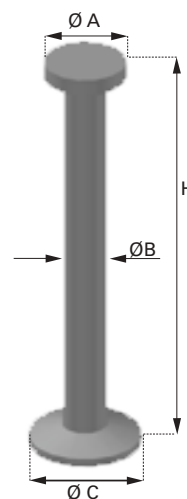

Chiodo T Anchor								
Nero	Zinc. a caldo	Carico	Altezza H	Ø A	Ø B	Ø C	Peso	Marchio
Black	H.D.G.	Load group	Height H	mm	mm		Kg/pz	Brand
		kN	mm	mm	mm			GL
T-13-035	T-13-035-TV	13	35	19	10	25	0,044	
T-13-040	T-13-040-TV	13	40	19	10	25	0,047	
T-13-050	T-13-050-TV	13	50	19	10	25	0,053	
T-13-055	T-13-055-TV	13	55	19	10	25	0,056	
T-13-065	T-13-065-TV	13	65	19	10	25	0,062	
T-13-085	T-13-085-TV	13	85	19	10	25	0,075	
T-13-120	T-13-120-TVCE	13	120	19	10	25	0,096	GL
T-13-240	T-13-240-TV	13	240	19	10	25	0,170	
T-25-045	T-25-045-TV	25	45	26	14	35	0,109	
T-25-055	T-25-055-TV	25	55	26	14	35	0,122	
T-25-065	T-25-065-TV	25	65	26	14	35	0,134	
T-25-070	T-25-070-TV	25	70	26	14	35	0,140	
T-25-085	T-25-085-TV	25	85	26	14	35	0,158	
T-25-100	T-25-100-TV	25	100	26	14	35	0,176	
T-25-120	T-25-120TVCE	25	120	26	14	35	0,200	GL
T-25-140	T-25-140-TV	25	140	26	14	35	0,225	
T-25-170-CE	T-25-170TVCE	25	170	26	14	35	0,261	GL
T-25-210	T-25-210-TV	25	210	26	14	35	0,309	
T-25-240	T-25-240-TV	25	240	26	14	35	0,345	
T-25-280	T-25-280-TV	25	280	26	14	35	0,394	
T-40-170	T-40-170TVCE	40	170	36	20	50	0,261	GL
T-50-055	T-50-055-TV	50	55	36	20	50	0,271	
T-50-065	T-50-065-TV	50	65	36	20	50	0,296	
T-50-075	T-50-075-TV	50	75	36	20	50	0,321	
T-50-080	T-50-080-TV	50	80	36	20	50	0,333	
T-50-085	T-50-085-TV	50	85	36	20	50	0,350	
T-50-095	T-50-095-TV	50	95	36	20	50	0,370	
T-50-110	T-50-110-TV	50	110	36	20	50	0,407	
T-50-120	T-50-120-TV	50	120	36	20	50	0,432	
T-50-140	T-50-140-TV	50	140	36	20	50	0,480	
T-50-150	T-50-150-TV	50	150	36	20	50	0,505	
T-50-160	T-50-160-TV	50	160	36	20	50	0,516	
T-50-170	T-50-170-TV	50	170	36	20	50	0,555	
T-50-180	T-50-180-TVCE	50	180	36	20	50	0,580	GL
T-50-210	T-50-210-TV	50	210	36	20	50	0,654	
T-50-240	T-50-240-TV-CE	50	240	36	20	50	0,728	GL
T-50-340	T-50-340-TV-CE	50	340	36	20	50	0,974	GL
T-50-480	T-50-480-TV	50	480	36	20	50	1,320	
T-50-680	T-50-680-TV	50	680	36	20	50	1,812	

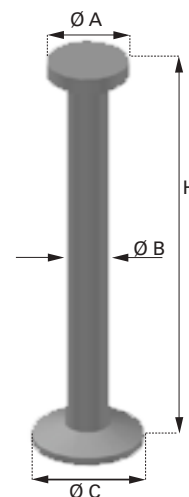

Chiodo T Anchor								
Nero Black	Zinc. a caldo H.D.G.	Carico Load group	Altezza H Height H	Ø A	Ø B	Ø C	Peso Weight	Marchio Brand
		kN	mm	mm	mm		Kg/pz	GL
T-75-085	T-75-085-TV	75	85	46	24	60	0,572	
T-75-095	T-75-095-TV	75	95	46	24	60	0,608	
T-75-100	T-75-100-TV	75	100	46	24	60	0,626	
T-75-120	T-75-120-TV	75	120	46	24	60	0,697	
T-75-140	T-75-140-TV	75	140	46	24	60	0,768	
T-75-150	T-75-150-TV	75	150	46	24	60	0,803	
T-75-160	T-75-160-TV	75	160	46	24	60	0,838	
T-75-165	T-75-165-TV	75	165	46	24	60	0,857	
T-75-170	T-75-170-TV	75	170	46	24	60	0,875	
T-75-200CE	T-75-200TVCE	75	200	46	24	60	0,981	GL
T-75-240	T-75-240-TV	75	240	46	24	60	1,123	
T-75-300CE	T-75-300TVCE	75	300	46	24	60	1,336	GL
T-75-540	T-75-540-TV-CE	75	540	46	24	60	2,192	GL
T-75-680	T-75-680-TV	75	680	46	24	60	2,690	
T-100-085	T-100-085-TV	100	85	46	28	70	0,714	
T-100-090	T-100-090-TV	100	90	46	28	70	0,765	
T-100-100	T-100-100-TV	100	100	46	28	70	0,815	
T-100-110	T-100-110-TV	100	110	46	28	70	0,863	
T-100-115	T-100-115-TV	100	115	46	28	70	0,887	
T-100-120	T-100-120-TV	100	120	46	28	70	0,910	
T-100-135	T-100-135-TV	100	135	46	28	70	0,984	
T-100-140	T-100-140-TV	100	140	46	28	70	1,007	
T-100-150	T-100-150-TV	100	150	46	28	70	1,056	
T-100-170CE	T-100-170-TV-CE	100	170	46	28	70	1,153	GL
T-100-200	T-100-200-TV	100	200	46	28	70	1,298	
T-100-220	T-100-220-TV	100	220	46	28	70	1,395	
T-100-250CE	T-100-250TVCE	100	250	46	28	70	1,540	GL
T-100-340CE	T-100-340TVCE	100	340	46	28	70	1,974	GL
T-100-500	T-100-500-TV	100	500	46	28	70	2,748	
T-100-540	T-100-540-TV	100	540	46	28	70	2,940	
T-100-650	T-100-650-TV	100	650	46	28	70	3,473	
T-100-680CE	T-100-680-TVCE	100	680	46	28	70	3,315	GL
T-100-1300	T-100-1300-TV	100	1300	46	28	70	6,615	
T-150-140	T-150-140-TV	150	140	70	38	80	1,992	
T-150-150	T-150-150-TV	150	150	70	38	80	2,080	
T-150-165	T-150-165-TV	150	165	70	38	80	2,214	
T-150-170	T-150-170-TV	150	170	70	38	80	2,258	
T-150-200	T-150-200-TV	150	200	70	38	80	2,526	
T-150-210	T-150-210-TV	150	210	70	38	80	2,615	



Lifting T anchors

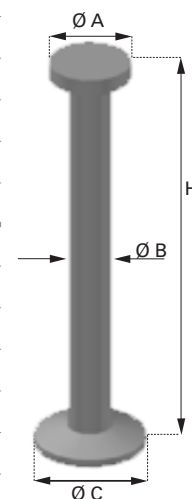

Chiodo T Anchor								
Nero	Zinc. a caldo	Carico	Altezza H	Ø A	Ø B	Ø C	Peso	Marchio
Black	H.D.G.	Load group	Height H	mm	mm	mm	Weight	Brand
		kN	mm	mm	mm		Kg/pz	GL
T-150-300	T-150-300-TV-CE	150	300	70	38	80	3,416	GL
T-150-400CE	T-150-400-TVCE	150	400	70	38	80	4,306	GL
T-150-840	T-150-840-TV	150	840	70	38	80	8,223	
T-200-100	T-200-100-TV	200	100	70	40	93	1,965	
T-200-165	T-200-165-TV	200	165	70	40	93	2,606	
T-200-170	T-200-170-TV	200	170	70	40	93	2,655	
T-200-200	T-200-200-TV	200	200	70	40	93	2,951	
T-200-240	T-200-240-TV	200	240	70	40	93	3,346	
T-200-250	T-200-250-TV	200	250	70	40	93	3,445	
T-200-340	T-200-340-TV-CE	200	340	70	40	93	4,332	GL
T-200-500	T-200-500-TV-CE	200	500	70	40	93	5,911	GL
T-200-1000	T-200-1000-TV	200	1000	70	40	93	10,843	
T-320-175	T-320-175-TV	320	175	88	50	135	5,419	
T-320-280	T-320-280-TV	320	280	88	50	135	7,038	
T-320-320	T-320-320-TV	320	320	88	50	135	7,654	
T-320-500	T-320-500-TV-CE	320	500	88	50	135	10,429	
T-320-700	T-320-700-TV	320	700	88	50	135	13,512	
T-320-1200	T-320-1200-TV	320	1200	88	50	135	21,218	
T-450-280	T-450-280-TV	450	280	88	50	135	7,038	
T-450-500	T-450-500-TV	450	500	88	50	135	10,429	
T-450-700	T-450-700-TV	450	700	88	50	135	13,512	
T-450-1200	T-450-1200-TV	450	1200	88	50	135	21,218	

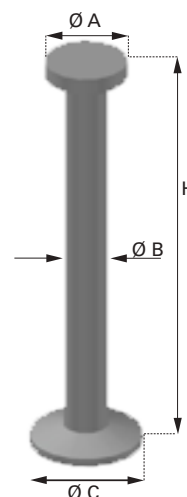
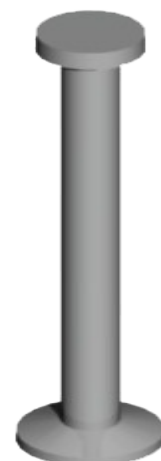

Chiodo a ribaltamento TR

TR Rolling anchor

Chiodo a ribaltamento TR Rolling anchor						
Zinc. a caldo	Carico	Altezza H	Ø A	Ø C	Peso	Marchio
H.D.G.	Load group	Height H	mm	mm	Weight	Brand
		kN	mm	mm	Kg/pz	GL
TR-25-200-TVCE	25	200	25	15	0,50	GL
TR-50-200-TVCE	50	200	36	20	1,16	GL

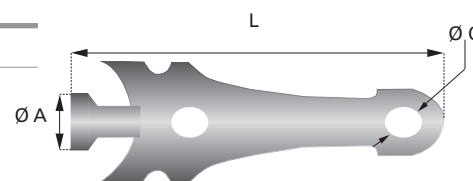

Chiodo O



O Anchor

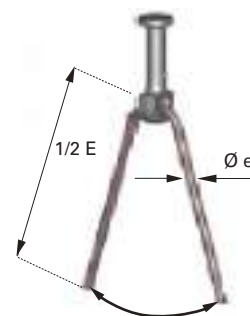
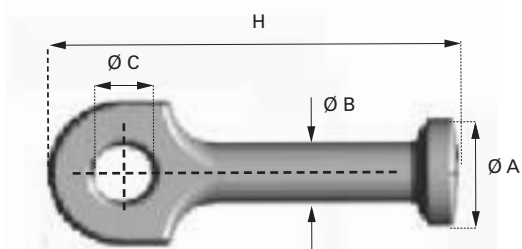

Chiodo O a occhio - O Anchor

Nero Black	Zinc. a caldo H.D.G.	Carico Load group	H	Ø A	Ø B	Ø C	Ø e	E	Peso Weight	Marchio Brand
		kN	mm	mm	mm	mm	mm	mm	Kg/pz	GL
O-13-065	O-13-065-TV	13	65	19	10	9	8	450	0,062	
O-25-090	O-25-090-TV	25	90	25	14	13	10	600	0,171	GL
O-25-120	O-25-120-TV	25	120	25	14	13	10	600	0,207	
O-50-090	O-50-090-TV	50	90	36	20	18	16	900	0,351	
O-50-120	O-50-120-TV	50	120	36	20	18	16	900	0,425	GL
O-100-115	O-100-115-TV	100	115	47	28	25	20	1100	0,820	
O-100-180	O-100-180-TV	100	180	47	28	25	20	1100	1,147	GL
O-200-250	O-200-250-TV	200	250	70	39	37	32	1700	3,311	
O-320-300	O-320-300-TV	320	300	88	50	47	40	2100	6,254	

Chiodo P

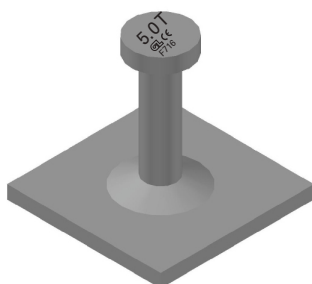

P Anchor

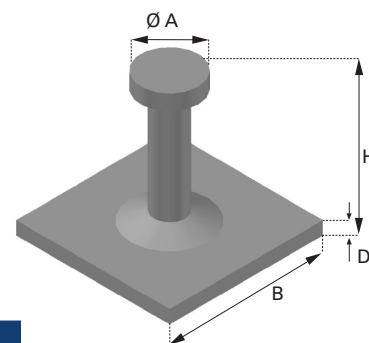

Chiodo P Anchor

Nero Black	Zinc. a caldo H.D.G.	Carico Load group	H	Ø A	B	D	Peso Weight	Marchio Brand
		kN	mm	mm	mm	mm	Kg/pz	GL
P-25-055	P-25-055-TV	25	55	26	70	6	0,324	GL
P-25-085	P-25-085-TV	25	85	26	70	6	0,360	
P-25-120	P-25-120-TV	25	120	26	70	6	0,402	
P-50-055	P-50-055-TV	50	55	36	90	8	0,708	
P-50-065	P-50-065-TV	50	65	36	90	8	0,733	GL
P-50-095	P-50-095-TV	50	95	36	90	8	0,807	
P-50-110	P-50-110-TV	50	110	36	90	8	0,844	
P-100-115	P-100-115-TV	100	115	46	90	10	1,381	

Chiodo TKS

I chiodi TKS sono forgiati a caldo da barre ad aderenza migliorata, sono progettati per il sollevamento di carichi da 25 kN a 150 kN.

I chiodi TKS vengono impiegati nei manufatti sottili dove non è possibile impiegare i chiodi T perchè lo spessore del manufatto in calcestruzzo non consente lo sviluppo del cono.

TKS anchor

Hot-forged from rebar steel with improved adherence, TKS slot anchor are designed for load force in the range of 25 kN to 150 kN.

The TKS anchor are used in slender elements where it is not possible to use T anchors because the thickness of the concrete element does not allow the development of the cone.

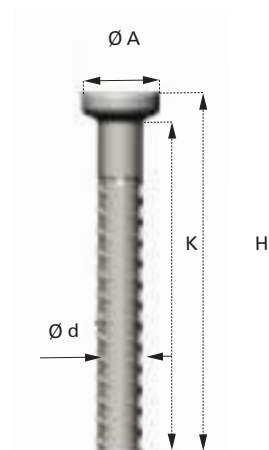

Chiodo TKS Anchor

Nero Black	Carico Axial load kN	H mm	K mm	Ø d mm	Ø A mm	Peso Weight Kg/pz
TKS-025-0400	25	400	374	14	26	0,505
TKS-025-0520	25	520	494	14	26	0,645
TKS-050-0580	50	580	548	20	36	1,460
TKS-050-0790	50	790	758	20	36	1,962
TKS-050-0900	50	900	868	20	36	2,230
TKS-075-0750	75	750	706	24	47	2,930
TKS-075-1150	75	1150	1106	24	47	4,352
TKS-100-0870	100	870	826	28	47	4,500
TKS-100-1300	100	1300	1256	28	47	6,450
TKS-150-1080	150	1080	1015	34	70	8,593
TKS-150-1550	150	1550	1485	34	70	11,935

Chiodo onda TWRA

TWRA wave anchor

Nero Black	Carico Axial load kN	H mm	L mm	Ø d mm	Ø A mm
TWRA-020-0145	20	145	38	14	26
TWRA-025-0190	25	190	38	14	26
TWRA-040-0230	40	230	53	20	36
TWRA-063-0270	63	270	63	25	46
TWRA-080-0300	80	300	80	28	46
TWRA-100-0325	100	325	80	28	46
TWRA-125-0350	125	350	95	32	70
TWRA-150-0400	150	400	103	36	70

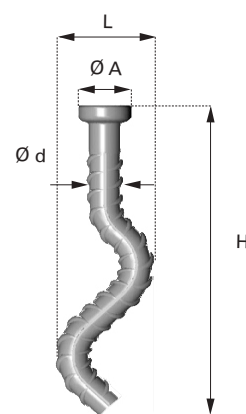

Per maggiori informazioni contattare i nostri tecnici

GL Locatelli si riserva di modificare ed aggiornare in qualsiasi momento le informazioni riportate in questo catalogo per il miglioramento continuo dell'informazione.

For more information contact our technical adviser

GL Locatelli reserves the right to modify and update at any time the information provided in this catalog for continuous improvement of information.

Forma monouso RBP		Form one use					
Codice	Carico	R	Ø A	B	Ø C	Ø D	H
Code	Load group						
	kN	mm	mm	mm	mm	mm	mm
RBP-25	25	37	14	7,5	14	80	39
RBP-40/50	50	47	15	11	20	100	48

Forma monouso in PP

One use former made in PP

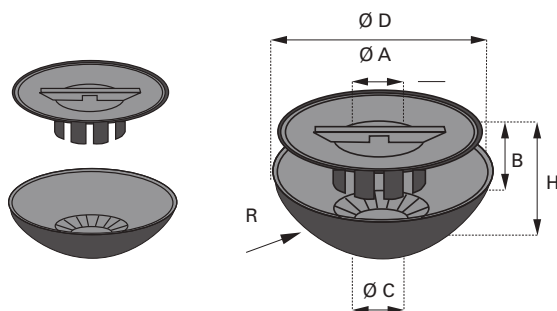

Forma RB Form		Form					
Codice	Carico	R	Ø A	B	Ø C	Ø D	H
Code	Load group						
	kN	mm	mm	mm	mm	mm	mm
RB-13	13	30	9,5	9	10	66	32
RB-25	25	37	14	7,5	14	80	39
RB-50	50	47	15	11	20	100	48
RB-75	75	60	15	10,5	24	128	61
RB-100	100	60	15	10,5	28	128	61
RB-150	150	80	19	10,5	38	170	80
RB-200	200	80	19	10,5	40	170	80
RB-320/450	320-450	108	22	15	50	236	107

Forma in gomma per usi ripetuti

Plastic gum recess former few use.

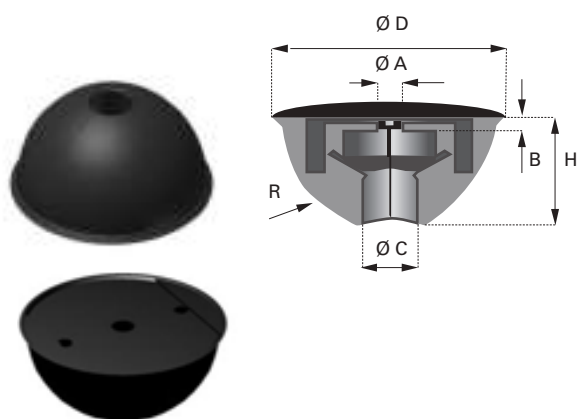

Tappo OPR		Mounting plate				
Codice	Carico	Forma RB		D	L	H
Code	Load group	Rubber recess former RB				
	kN	M		mm	mm	mm
OPR-013	13	RB013		66	100	17
OPR-025	25	RB025		80	100	20
OPR-050	50	RB050		100	100	26
OPR-075	75 - 100	RB075 / RB100		128	100	31
OPR-150	150 - 200	RB150 / RB200		170	100	39
OPR-320	320	RB320		236	100	54

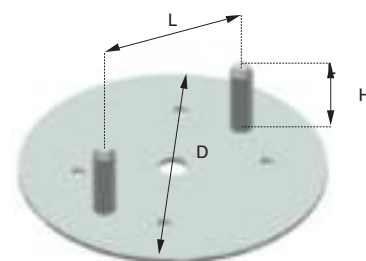

Forma SRB Form		Form					
Codice	Carico	Ø A	B	Ø C	M	N	H
Code	Load group						
	kN	mm	mm	mm	mm	mm	mm
SRB-013	13	9,5	7	10	37	47	29,5
SRB-025	25	14	6	14	44	59	39
SRB-050	50	15	8	20	60	78	49
SRB-075	75	15	8	24	77	97	58
SRB-100	100	15	8	28	77	97	58

Forma in gomma per manufatti a spessore ridotto

Plastic gum recess former for structures with low thickness

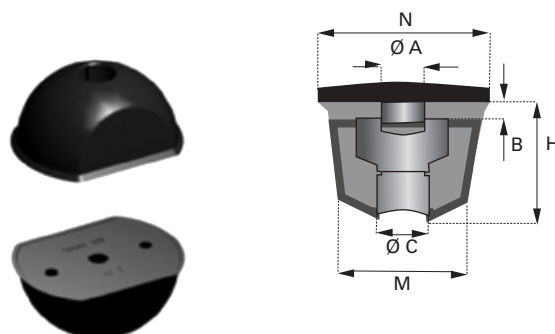

Piatto IPK Plate				
Codice	Carico	L	H	B
Code	Load group			
	kN	mm	mm	mm
IPK-13	13	54	16	15
IPK-25	25	67	16	20
IPK-50	50	84	24	25

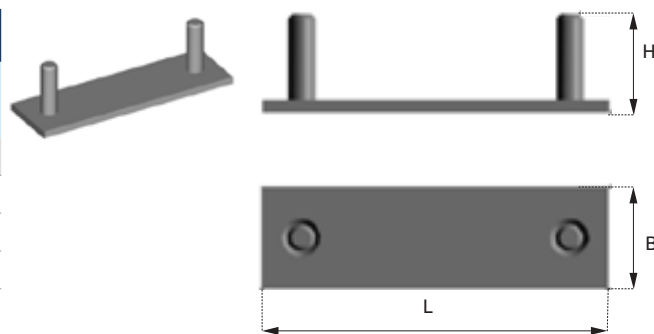

Per Forma in gomma per manufatti a spessore ridotto

For plastic gum recess former for structures with reduced thickness

Forma SBK Form							
Codice	Carico	Ø A	B	Ø C	Ø D	R	H
Code	Load group						
	kN	mm	mm	mm	mm	mm	mm
SBK-013	13	M12	11	19,9	63	32	36
SBK-025	25	M12	11	26,9	80	69	43,5
SBK-050	50	M12	13	36,9	101	65	54
SBK-100	100	M16	15	47,1	129	80	72

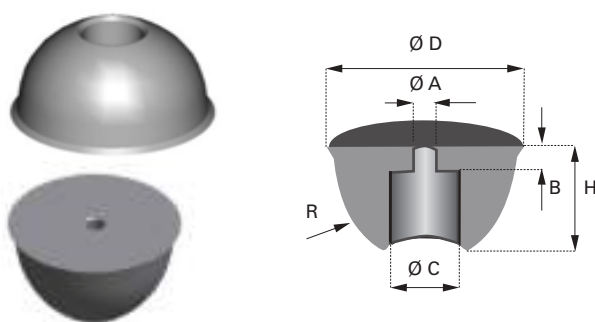

Forma in acciaio

Steel recess former

Forma SBKM Form							
Codice	Carico	Ø A	B	Ø C	Ø D	R	H
Code	Load group						
	kN	mm	mm	mm	mm	mm	mm
SBKM-013	13	M12	11	20	66,5	32	36
SBKM-025	25	M12	11	30	80	69	43,5
SBKM-050	50	M12	13	37	100	65	54
SBKM-100	100	M16	15	48	129	80	72

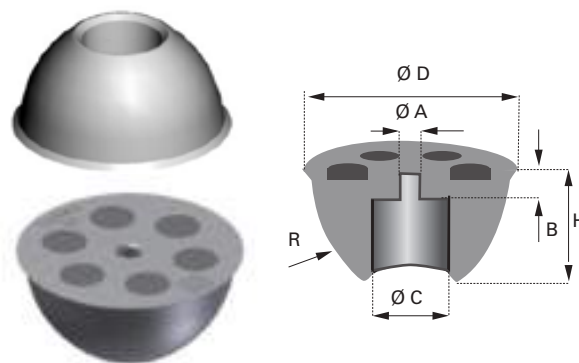

Forma in acciaio magnetica

Magnetic steel recess former

Anello RR Oring				
Codice	Carico	Ø D	Ø d	H
Code	Load group			
	kN	mm	mm	mm
RR-013	13	21	10	11
RR-025	25	31	14	12
RR-050	50	38	20	14
RR-075	75	49	24	20
RR-100	100	49	28	20

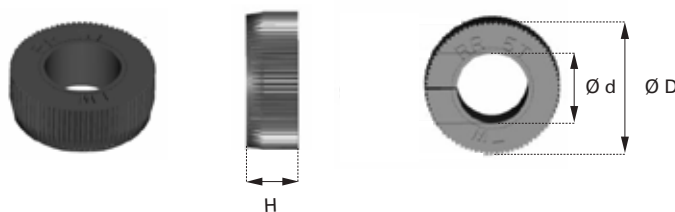

Per forma in acciaio

For steel recess former

Piatto IP Fixing plate		
Codice Code	Carico Load group	Filetto Thread
	kN	M
IP-013	13	M 8
IP-025	25	M10
IP-050	50	M10
IP-075	75 - 100	M12
IP-150	150 - 200	M12
IP-320	320	M16

Per forma in gomma For plastic gum recess former

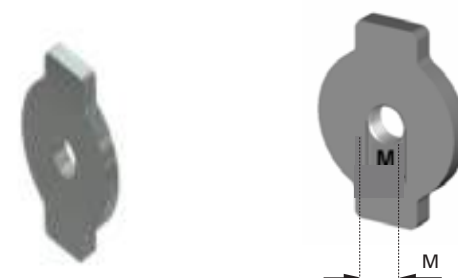

Inserto IPDV Fixing plate with thread rod			
Codice Code	Carico Load group	Filetto Thread	L
	kN	M	mm
IPDV13M08X100	13	M 8	100
IPDV25M10X100	25	M10	100
IPDV50M10X100	50	M10	100
IPDV75M12X100	75 - 100	M12	100
IPDV150/200	150 - 200	M12	100
IPDV320M16X100	320	M16	100

Per forma in gomma For plastic gum recess former

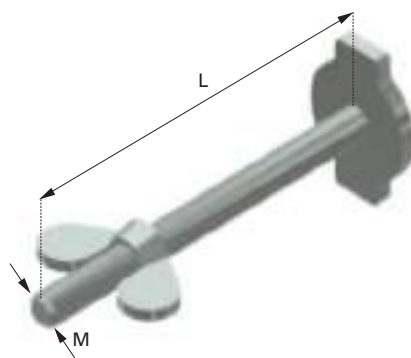

Se il cassero può essere rimosso solo di lato, fissare la forma usando la piastra di fissaggio con una barra filettata IPD o IPDV

If the formwork can only be removed sideways, the fixing plate with a threaded rod IPD or IPDV should be used.

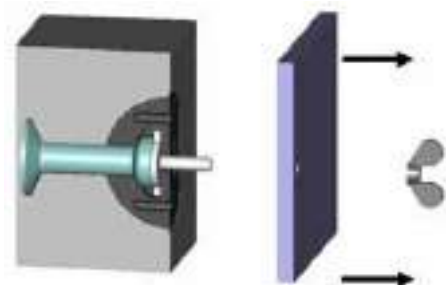

Barra filettata TDV Thread holding screw			
Codice Code	Carico Load group	Filetto Thread	L
	kN	M	mm
TDV-025	7 - 25	M8	160
TDV-050	30 - 50	M8	160
TDV-100	75 - 100	M12	160
TDV-200	125 - 220	M16	160

Se il cassero può essere rimosso verticalmente si deve usare la piastra di fissaggio IP in combinazione con le barre filettate TDV

If the formwork can only be removed vertically, the fixing plate IP in combination with the threaded screw TDV should be used.

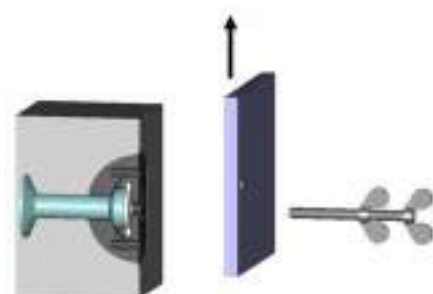
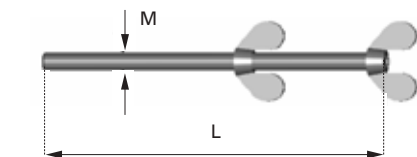

Maniglioni TH2 e THR2

La maniglia di sollevamento TH2 e THR2 sono in acciaio di alta qualità e progettati con un fattore di sicurezza pari a 5. Ogni maniglia è testata individualmente con carico di 3 volte il valore nominale e fornita con il proprio certificato. Il design della maniglia assicura una connessione corretta e sicura del chiodo.

La maniglia di sollevamento e il chiodo, corrispondono quando appartengono allo stesso gruppo di carico. Il gruppo di carico è segnato chiaramente sulla maniglia.

Utilizzare solo maniglie corrispondenti al carico indicato sul chiodo

TH2 and THR2 lifting clutches

The lifting clutch TH2 and THR2 are made of high quality steel and they are designed with a safety factor of 5. The lifting clutch is individually tested and is supplied with a unique certificate. The safety factor is 3 times the working load. The special design of the clutch ensure a tight and safe connection to the anchor. The lifting clutch, recess former and anchor only correspond when they are from the same load group. The load group is clearly marked on the lifting clutch.

Use only the clutches corresponding to the load shown on the anchor



Maniglione TH2 Clutch									
Codice	Carico	A	B	C	D	E	F	G	Peso
Code	Load group	mm	mm	mm	mm	mm	mm	mm	Weight
	kN	mm	mm	mm	mm	mm	mm	mm	Kg.
H2-13	13	48	77	60	55	40	33	165	0,944
H2-25	25	50	92	75	68	55	42	205	1,770
H2-40/50	50	68	121	86	88	64	57	240	3,795
H2-75/100	100	84	170	110	108	90	77	346	9,390
H2-150/200	200	124	230	140	146	118	115	520	25,315
H2-320	320	155	303	175	195	160	155	590	50,400
H2-450	450	155	303	175	195	160	155	590	50,400

TH2

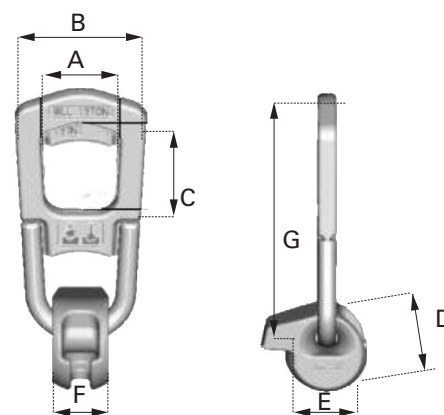

Maniglione THR2 Clutch											
Codice	Carico	A	B	C	d	L	D	E	F	G	Peso
Code	Load group	mm	mm	mm	mm	mm	mm	mm	mm	mm	Weight
	kN	mm	mm	mm	mm	mm	mm	mm	mm	mm	Kg.
HR2-40/50	50	66	106	60	20	80	88	64	57	180	2,789
HR2-75/100	100	90	146	58	28	68	108	90	77	210	5,881

THR2

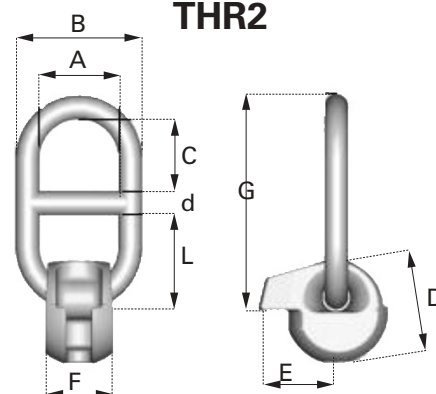

Istruzioni di sollevamento chiodi a T

Posizionare il maniglione sopra al chiodo

The clutch is brought in the right position.

Ricondurre il becco verso il basso nella posizione naturale in appoggio sul calcestruzzo

The shackle rotates to its locking position.

Il peso del becco consente alla sfera di rimanere agganciata al chiodo anche in assenza di carico.

Per sganciare il maniglione allentare il carico della maniglia in modo da consentire la rotazione della sfera affinché il becco possa ruotare verso l'alto liberando la sfera dal chiodo.

Due to the counterweight of the nose, the shackle remains connected, even in an unloaded state.

To release the clutch the load hook is lowerde and the shakle is turned up and out.

T anchors lifting instructions

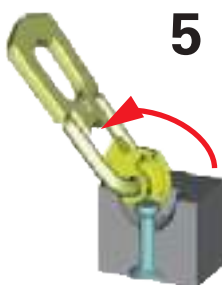
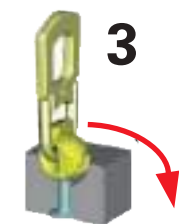

Ruotare il becco della sfera fintanto che la cavità possa accogliere la testa del chiodo.

Rotate the shackle, until the opening corresponds with the anchor head.

Non sollevare mai il carico se il becco della sfera non è correttamente a contatto del manufatto. Iniziare il sollevamento verticale. Il becco farà pressione sul manufatto in calcestruzzo.

The nose of the shackle is pushed against the concrete element.

Solo quando la sfera è completamente staccata dal chiodo e dal manufatto, si può ritirare la gru.

Il maniglione può rimanere agganciato all'uncino della gru per una movimentazione successiva.

Only after the Lifting System is completely detached of the recess and anchor, the crane can be withdrawn. The lifting clutch can remain attached to the crane hook till another use.

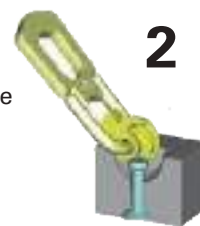

Tiro inclinato

Per tiri inclinati, o per la rotazione del manufatto, verificare che il becco si trovi sempre rivolto verso il tiro

Cable angle

For cable angle or for the rotation of the concrete element, verify that the nose is always in the direction of the load.

Non sollevare mai il carico se il becco della sfera non è correttamente a contatto del manufatto.

Il sollevamento e la movimentazione di manufatti in calcestruzzo sono operazioni delicate che richiedono la massima attenzione da parte degli operatori.

Manovre improvvise, violente e scorrette possono provocare la caduta del manufatto con danni gravi alle strutture ed alle persone nelle vicinanze.

Non transitare né sostare sotto ai carichi sospesi.

In caso di dubbio non procedere con il sollevamento.

Consultare il personale esperto e competente

Never lift the load if the nose of the shackle is not correctly in contact with the elements.

The lifting and the moving of the concrete element, are delicate operations which require maximum attention from the operators.

Sudden, violent and wrong movement can cause the falling of the element with serious damages to the structure and to the people nearby.

Never pass by or stay still under suspended loads.

In case of doubt never proceed with the lifting and ask for advice to expert and competent personell.

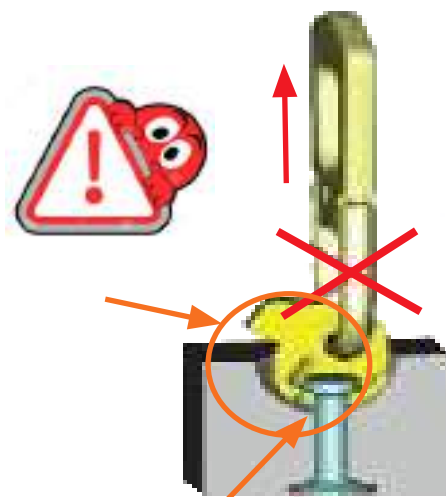
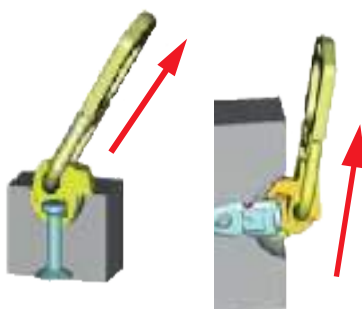

Attenzione

Ogni maniglione riporta un **Codice di identificazione** che deve essere ben visibile.
Il maniglione deve essere integro e le zone soggette ad usura devono essere controllate almeno 2 volte all'anno.

Calibro 3D per verifica dello stato di usura della sfera

Se si riscontrano deformazioni, allungamenti, o l'allargamento dell'imboccatura il **maniglione deve essere rimosso e rottamato**.

Se le misure H ed M sono diverse o inferiori ai valori in tabella, il maniglione **deve essere rimosso e rottamato**.

E' severamente vietato l'uso di maniglioni riparati o modificati, in particolare non si possono eseguire saldature.

Non combinare Maniglioni e chiodi di diversi produttori.

L'acquisto dei componenti di sollevamento da un unico fornitore offre maggiori garanzie all'utilizzatore sul controllo delle tolleranze dei componenti del sistema.

H larghezza massima consentita per l'uso della maniglia, il calibro non passa

M spessore minimo consentito per l'uso della maniglia.

Attention

Each clutch contains an **Identification code** that must be clearly visible.
The handle must be intact and the areas subject to wear must be checked at least 2 a year.

The handle must be intact and the areas subject to wear must be checked at least 2 a year.

3D caliber for checking the wear condition of the sphere

If deformations, elongations, or enlargement of the mouth occur, **the handle must be removed and thrown away**.

If the H and M measurements are different or lower than the values in the table, **the clutch must be removed and thrown away**.

It is strictly forbidden to use repaired or modified clutches, in particular no welding can be carried out.
Do not combine clutches and anchors of different manufacturers.

The purchase of lifting components from a single supplier offers greater guarantee to the user on the system tolerance check.

H Maximum allowable width for the clutch use, the caliber does not pass
M minimum allowable thickness for the clutch use.



calibro3D per verifica dello stato 3D lifting system checking caliber

Maniglione Clutch	H max mm	M min mm	Calibro "passa /non passa" Caliber "Go/No Go number"
H2-13	13	5,5	46193
H2-25	18	7	46194
H2-40/50	24	9	46195
H2-75/100	33	12	46196
H2-150/200	45	18	46197
H2-320	56	25	46198
H2-450	56	25	46199

THR2

Maniglione Clutch	H max mm	M min mm	Calibro "passa /non passa" Caliber "Go/No Go number"
HR2-40/50	24	9	46195
HR2-75/100	33	12	46196

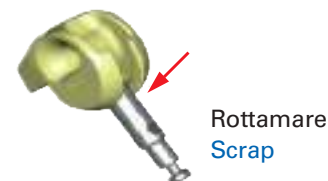
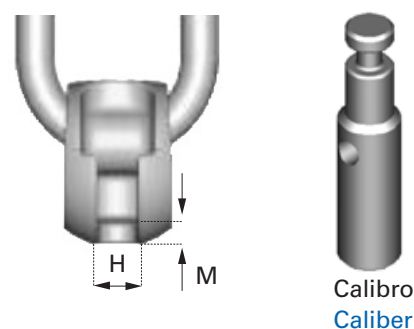

Controllo dimensione M

La dimensione M della sfera consente di verificare lo spessore soggetto ad usura

Dimension M check

The dimension M must be checked in this zone with risk of fracture during usage

Accettabile

La dimensione M è maggiore del minimo consentito e non entra nel calibro

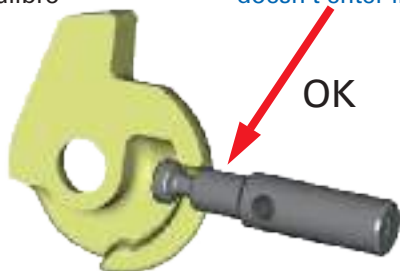

Acceptable

Dimension M is higher than the allowed minimum and doesn't enter into the caliber

NON Accettabile

La dimensione M è minore del minimo consentito e entra nel calibro

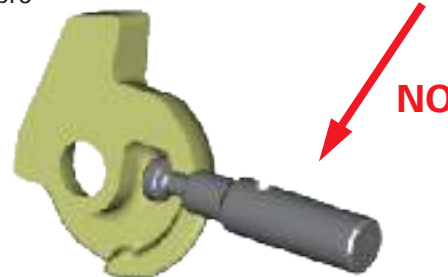

NOT Acceptable

Dimension M is less than the allowed value.

Controllo dimensione H

La dimensione H della sfera deve essere verificata almeno in 3 punti diversi della lunghezza. L'usura provoca l'allargamento localizzato o diffuso.

Dimension H check C

The H dimension must be checked in at least 3 zones with risk of enlargement during usage. Overuse provoke localized or diffused enlargement.



Accettabile

La dimensione H è minore del massimo consentito, e il calibro non passa

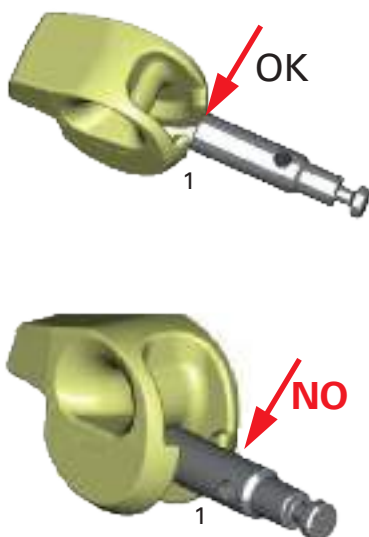

Acceptable

Dimension H is less than the allowed maximum

NON Accettabile

La dimensione H è maggiore del minimo consentito e il calibro passa

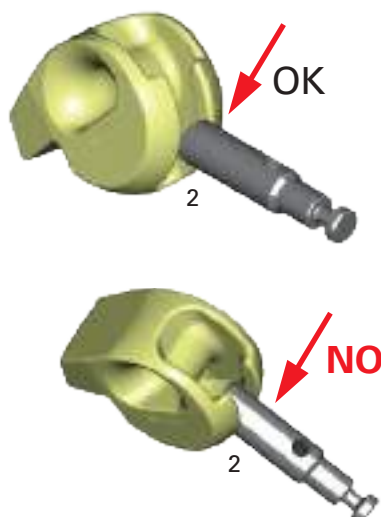

NOT Acceptable

Dimension H is larger than the minimum allowed.

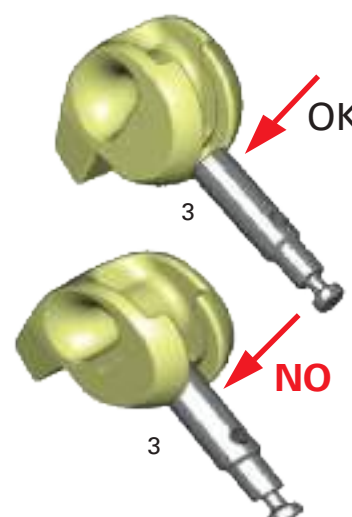

GL Locatelli raccomanda all'utilizzatore che la verifica delle sfere sia periodica e costante. L'uso periodico del calibro, per la verifica dell'usura ed un'attenta valutazione sullo stato dei maniglioni consentono di lavorare in sicurezza. L'impiego di maniglioni degradati, deformati e sotto delle dimensioni indicate è pericoloso ed è vietato. L'uso di maniglioni idonei e la rottamazione dei maniglioni usurati o danneggiati spetta all'utilizzatore. GL Locatelli declina ogni responsabilità derivante dall'uso di materiale degradato o impiegato impropriamente

GL Locatelli recommends to the user the constant use of the calibrator for the verification of the wear and an attentive evaluation of the status of the clutches. The use of ruined and deformed clutches and under the recommended dimensions is dangerous and forbidden. The use of idoneous clutches and the scrapping of worn or damaged clutches is a duty of the user. GL Locatelli declines any responsibility deriving from the use degraded material or inappropriately used.

Zanche SA-B

Le zanche SA-B sono progettate per un intervallo di carico da 7 kN a 220kN. Queste sono facilmente adattabili e forniscono un efficiente ancoraggio per pannelli sottili e solai.

Sono usate anche in colonne e travi. Per impieghi particolari aggiungere l'armatura nel foro supplementare.

SA-B erection

The SA-B anchors are designed to load range 7 kN to 220 kN.

They are easy adaptable and they provide an efficient anchorage in thin panels and slabs. They are also used in columns, beams, trusses, slabs. In special cases, it is necessary to add reinforcement in the extra hole.

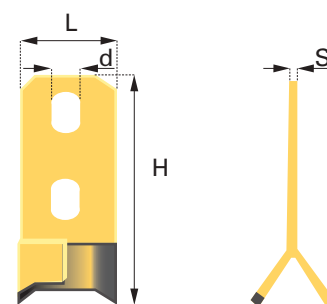
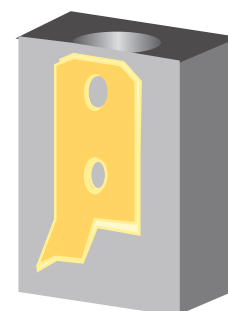

Zanca SA-B Erection								
Nero Black	Zinc. a caldo H.D.G. Galv.	Carico Load group	H	L	S	d	Peso Weight	Marchio Brand
		kN	mm	mm	mm	mm	Kg/pz	GL
SA-B-07-110	SA-B-07-110-TV	7	110	30	5	14	0,106	
SA-B-14-110	SA-B-14-110-TV	14	110	30	6	14	0,126	
SA-B-14-160	SA-B-14-160-TV	14	160	30	6	14	0,197	
SA-B-20-130	SA-B-20-130-TV	20	130	30	8	14	0,205	
SA-B-20-160	SA-B-20-160-TV	20	160	30	8	14	0,262	
SA-B-20-210	SA-B-20-210-TV	20	210	30	8	14	0,356	
SA-B-25-120	SA-B-25-120-TV	25	120	30	10	14	0,233	
SA-B-25-150	SA-B-25-150-TV	25	150	30	10	14	0,304	GL
SA-B-25-200	SA-B-25-200-TV	25	200	30	10	14	0,422	
SA-B-25-250	SA-B-25-250-TV	25	250	30	10	14	0,540	
SA-B-30-160	SA-B-30-160-TV	30	160	40	10	18	0,432	
SA-B-30-220	SA-B-30-220-TV	30	220	40	10	18	0,558	
SA-B-30-280	SA-B-30-280-TV	30	280	40	10	18	0,809	
SA-B-40-140	SA-B-40-140-TV	40	140	40	12	18	0,446	
SA-B-40-180	SA-B-40-180-TV	40	180	40	12	18	0,597	
SA-B-40-240	SA-B-40-240-TV	40	240	40	12	18	0,823	
SA-B-40-320	SA-B-40-320-TV	40	320	40	12	18	1,124	
SA-B-50-180	SA-B-50-180-TV	50	180	40	15	18	0,745	GL
SA-B-50-240	SA-B-50-240-TV	50	240	40	15	18	1,028	
SA-B-50-400	SA-B-50-400-TV	50	400	40	15	18	1,781	
SA-B-53-220	SA-B-53-220-TV	53	220	60	12	26	1,081	
SA-B-53-260	SA-B-53-260-TV	53	260	60	12	26	1,307	
SA-B-53-340	SA-B-53-340-TV	53	340	60	12	26	1,759	
SA-B-75-260	SA-B-75-260-TV	75	260	60	15	26	1,633	GL
SA-B-75-300	SA-B-75-300-TV	75	300	60	15	26	1,916	
SA-B-75-420	SA-B-75-420-TV	75	420	60	15	26	2,764	
SA-B-100-300	SA-B-100-300-TV	100	300	60	20	27	2,537	GL
SA-B-100-370	SA-B-100-370-TV	100	370	60	20	27	3,197	
SA-B-100-520	SA-B-100-520-TV	100	520	60	20	27	4,610	
SA-B-140-370	SA-B-140-370-TV	140	370	80	20	35	4,074	
SA-B-140-460	SA-B-140-460-TV	140	460	80	20	35	5,217	
SA-B-220-500	SA-B-220-500-TV	220	500	80	25	35	7,127	
SA-B-220-620	SA-B-220-620-TV	220	620	80	25	35	9,026	

GL : prodotti frequenti

GL : high turnover product

Zanche SA-TTU

Le zanche SA-TTU servono per il ribaltamento dei manufatti. Sono usate per carichi tra 14kN a 100kN.

Le applicazioni principali sono: manufatti in cemento snelli come le pareti, sollevati dalla posizione orizzontale alla verticale. La testata ancorante è progettata appositamente riduce la pressione sul calcestruzzo. Normalmente questo ancoraggio è usato con armatura aggiuntiva per il corretto ribaltamento del manufatto.

SA-TTU erection anchor

The tilt up erection anchors SA-TTU are used for tilting concrete elements. They are used for loads between 14kN and 100 kN.

The main uses are concrete elements slender as wall, lifted from a horizontal to a vertical position. The anchor head is designed on purpose for reducing the pressure on concrete.

Normally this anchor is used as additional reinforcement for the right tilting of the concrete element.

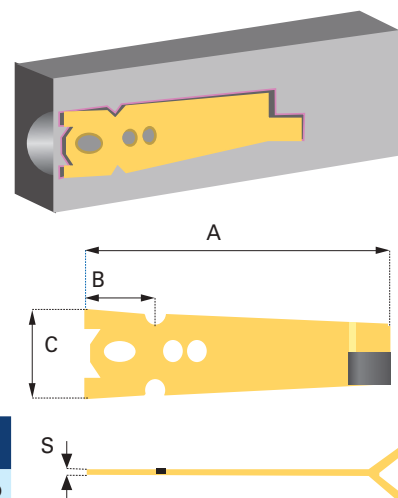

Lifting erection anchors

Zanca a ribaltamento		SA-TTU	Tilt up anchor				Peso	Marchio
Nero	Zinc. a caldo	carico	A	B	C	S	Peso	Marchio
Black	H.D.G. Galv.	Load group	mm	mm	mm	mm	Kg/pz	Brand
		kN	mm	mm	mm	mm	Kg/pz	GL
SA-TTU-14-200	SA-TTU-14-200TV	14	200	45	55	6	0,382	
SA-TTU-25-150	SA-TTU-25-150TV	25	150	45	55	10	0,492	
SA-TTU-25-230	SA-TTU-25-230TV	25	230	45	55	10	0,711	GL
SA-TTU-40-270	SA-TTU-40-270TV	40	270	70	70	12	1,308	
SA-TTU-50-290	SA-TTU-50-290TV	50	290	70	70	15	1,906	GL
SA-TTU-75-320	SA-TTU-75-320TV	75	320	90	95	18	3,453	GL
SA-TTU-100-390	SA-TTU-100-390TV	100	390	90	95	20	4,610	GL

Forma		RBF	Recess former		
Codice	carico	A	B	C	Filetto
Code	Load group	mm	mm	mm	Thread
		kN	mm	mm	mm
RBF-015	12,5 - 15	29	62	35	M8
RBF-025	7 - 25	43	104	45	M8
RBF-050	30 - -50	49	126	59	M8
RBF-100	75 - 100	67	188	85	M12
RBF-250	125 - 260	112	233	121	M16

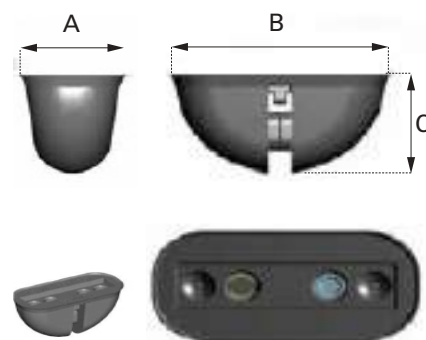

Piastra di tenuta		TMP	Holding plate		
Codice	carico	H	L	S	d
Code	Load group	mm	mm	mm	mm
		kN	mm	mm	mm
TMP-015	12,5 - 15	45	15	3	6
TMP-025	7 - 25	73	15	4	10
TMP-050	30 - -50	85	30	4	10
TMP-100	75 - 100	128	40	6	12
TMP-250	125 - 260	178	65	8	16

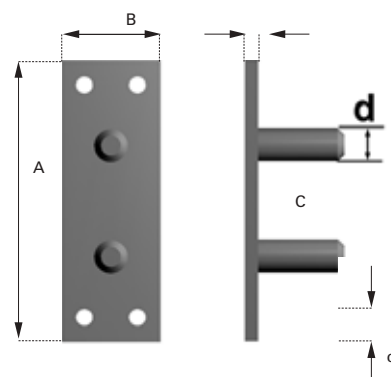

Barra filettata TDV Holding screw			
Codice Code	carico Load group	L	d
	kN	mm	mm
TDV025	7 - 25	160	8
TDV050	30 - 50	160	8
TDV100	75 - 100	160	12
TDV200	125 - 220	180	16

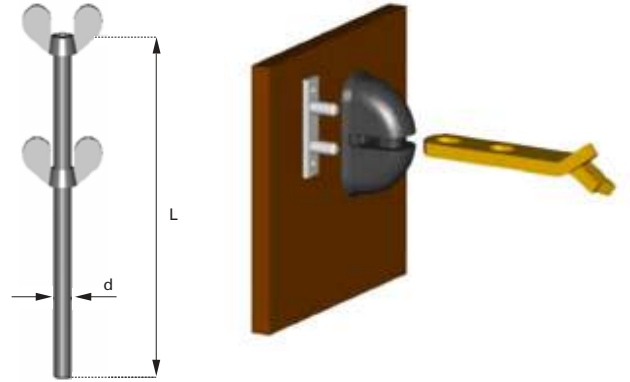

Maniglioni sistema 2D 2D-system lifting clutches

Maniglione TF1 Lifting clutch							
Zincata Galvanized	Carico max Maximum load	Carico Load Group	A	B	C	d	Peso Weight
	kN	kN	mm	mm	mm	mm	Kg/pz
TF1-0125	12,5	12,5	100	54	176	9	0,56
TF1-015	15	15	100	54	176	9	0,56
TF1-025	25	7-25	120	90	195	14	1,6
TF1-050	50	30-50	200	100	295	18	3,8
TF1-100	100	53-100	240	140	325	22	8,2
TF1-260	260	125-260	1570	160	480	32	34,4

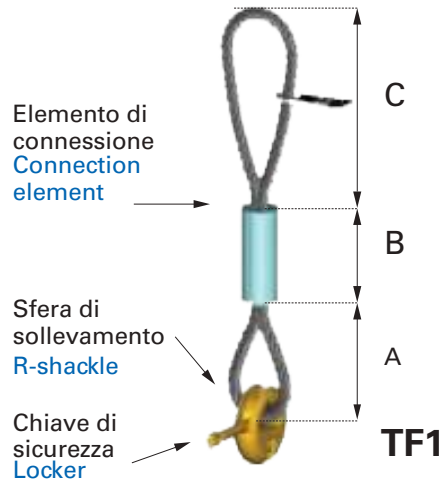
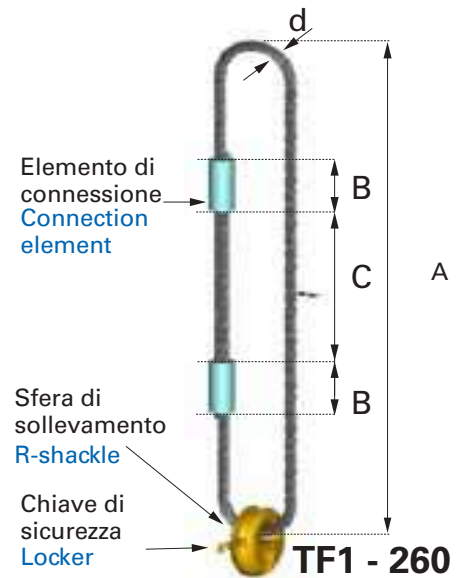

Maniglione TF2 Lifting clutch								
Zincata Galvanized	Carico max Maximum load	Carico Load Group	A	B	C	D	E	Peso Weight
	kN	kN	mm	mm	mm	mm	mm	Kg/pz
TF2-025	25	7-25	259	27	78,5	70	50	1,7
TF2-050	50	30-50	325	36	105	86	58	3,9
TF2-100	100	53-100	431	50	146,7	107	75	9,5
TF2-260	260	125-260	620	72	216	154	110	20,7

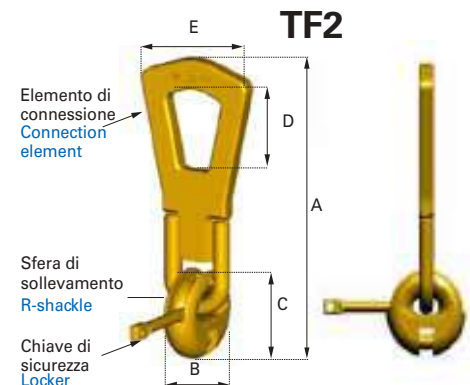

Istruzioni di sollevamento delle zanche **Erection lifting instructions**

Rimuovere la forma in gomma aprendola come nella figura 1

Remove the recess former, opening it as shown in figure 1

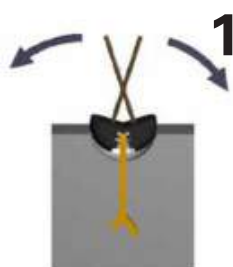

Ruotare il perno della sfera in modo da aprire il chiavistello e la cavità possa accogliere la zanca.

Rotate the shackle, until the opening corresponds with the anchor head and the cavity can allocate the erection anchor.

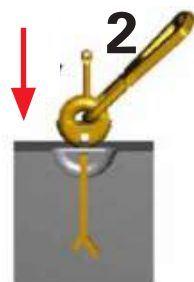

Ricondurre il perno verso il basso nella posizione naturale in appoggio sul calcestruzzo. Non sollevare mai il carico se il perno della sfera non è correttamente a contatto del manufatto.

The shackle rotates to its locking position.

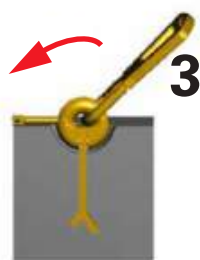

Iniziare il sollevamento verticale. Il becco farà pressione sul manufatto in calcestruzzo.

Start with the vertical lifting. The nose of the shackle is pushed against the concrete element.

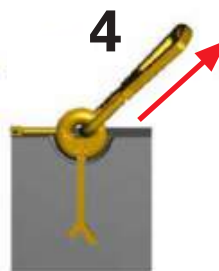

Il peso del perno consente alla sfera di rimanere agganciata alla zanca anche in assenza di carico.

Per sganciare il maniglione allentare il carico della maniglia in modo da consentire la rotazione del perno e l'uscita del chiavistello dall'asola.

Due to the counterweight of the nose, the shackle remains connected, even in an unloaded state.

To release the clutch the load hook is lowered and the shackle is turned up and out.

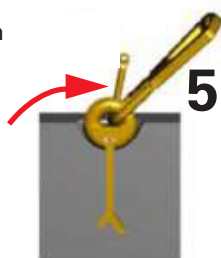

Solo quando la sfera è completamente staccata dalla zanca e dal manufatto, si può ritirare la gru.

Il maniglione può rimanere agganciato all'uncino della gru per una movimentazione successiva.

Only after the lifting system is completely detached from the erection anchor and from the concrete element, the crane can be withdrawn.

The lifting clutch can remain attached to the crane hook for another handling.

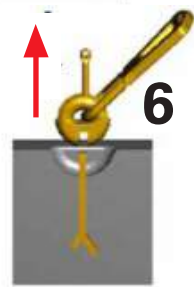

Ribaltamento

Per la rotazione del manufatto, verificare che il perno si trovi sempre rivolto nella direzione di tiro.

Tilting

For the rotation of the element, please verify that the nose is always in the direction of the pulling.

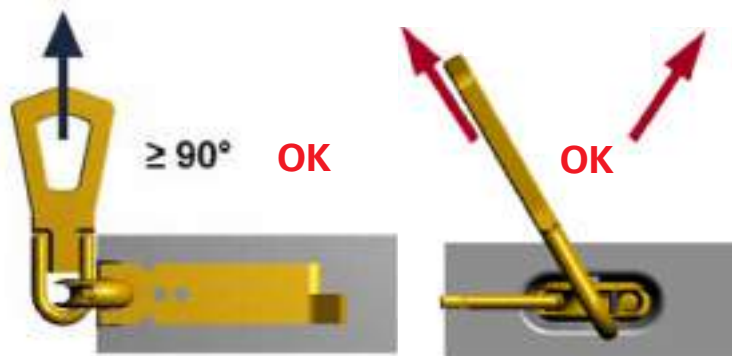

Non sollevare mai il carico se il perno della sfera non è correttamente a contatto del manufatto.

Il sollevamento e la movimentazione di manufatti in calcestruzzo sono operazioni delicate che richiedono la massima attenzione da parte degli operatori.

Manovre improvvise, violente o scorrette possono provocare la caduta del manufatto con danni gravi alle strutture ed alle persone nelle vicinanze.

Non transitare né sostare sotto ai carichi sospesi.

In caso di dubbio non procedere con il sollevamento e consultare il personale esperto e competente.

Never lift the load if the nose of the shackle is not correctly in contact with the elements.

The lifting and the moving of the concrete element, are delicate operations which require maximum attention from the operators.

Sudden, violent and wrong movement can cause the falling of the element with serious damages to the structure and to the people nearby.

Never pass by or stay still under suspended loads.

In case of doubt never proceed with the lifting and ask for advice to expert and competent personell.

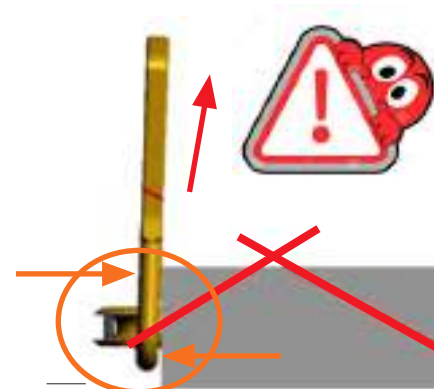

Verifica dello stato di usura della sfera

Chiavistello Locker		
Carico max	Dimensioni	Min. accettabile
Max. load	Dimention	Minimum acceptable
t	ø mm	ø mm
12,5+1,5	8+0,3/0	7,5
2,5	13+0,5/0	12
5,0	17+0,5/0	16
10,0	22+0,5/0	21
26,0	32+0,5/0	31

Sfera R-shackle		
Carico max	Dimensioni	Min. accettabile
Max. load	Dimention	Minimum acceptable
t	mm	mm
12,5+1,5	7+0,5/0	8
2,5	13+0,5/0	14
5,0	20+0,5/0	21
10,0	22+0,5/0	23
26,0	33+1,0/0	35

Attenzione

Ogni maniglione riporta un **Codice di identificazione** che deve essere ben visibile. Il maniglione deve essere integro e le zone soggette ad usura devono essere controllate almeno 2 volte all'anno.

Verifiche di sicurezza

Qualsiasi deformazione sul maniglione è indice di un sovraccarico pari a 3 volte il consentito, il maniglione deve essere rottamato e sostituito con uno nuovo. Non eseguire mai sollevamenti con un maniglione usurato o piegato. Se il maniglione presenta deformazioni o usure deve essere eliminato e rottamato. Le riparazioni sono vietate. Raccomandiamo fortemente di non combinare prodotti di diverse aziende previa opportune verifiche e autorizzazioni.

Controllo di treccie e cavi:

- attorcigliamento
- rottura di una treccia.
- separazione dello strato esterno della treccia.
- treccie sfilacciate.
- sfilacciamento di più di 4 cavi nel punto di contatto con la sfera di sollevamento o più di 10 cavi rotti sulla treccia.
- segni di corrosione.
- danneggiamento o usura della sfera di sollevamento

Lifting system check

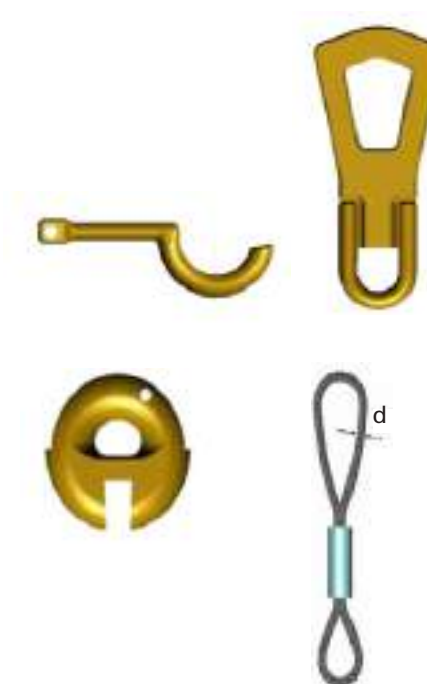

Maniglia Connection element		
Carico max	Dimensioni	Min. accettabile
Max. load	Dimention	Minimum acceptable
t	mm	mm
2,5	14	13
5,0	20	19
10,0	26	25
26,0	40	38,5

Maniglione Connection element		
Funi intrecciate Braided canles		
Numero di rotture visibili Number of visible ruptured wires over a lenght of		
3d	6d	30d
4	6	16

Attention

Each clutch contains an **Identification code** that must be clearly visible.

The handle must be intact and the areas subject to wear must be checked at least 2 a year.

Safety check

Any deformation on the clutch is a sign of wear equal to 3 times allowed: the clutch must be thrown away and substituted with a new one. Never carry out lifting with a weared on folded clutch. If the clutch shows deformation or wears it must be eliminated and thrown away.

Repairs are forbidden. We strongly recomend not to combine products of different companie after having camed out the proper checks and authorizations

Wire cables control:

- Kinking
- One braid breakafe
- Separating of the outer layer of braids
- Crushing braids
- Crushing at the R-shackle contact point with more than 4 ruptured wires on braided cables, or more than ruptured wires on cable laid rope
- Corrosion marks
- Damage or severe wear on the closing mechanism



		Boccole		Socket					
Zinc. elettr.	Filetto	Carico	L	D	l ₁	l ₂	d	Peso	
Electr.Galv.	Threaded	Load Group	mm	mm	mm	mm	mm	Kg/pz	Weight
	Rd	$f_{cu} > 15 \text{N/mm}^2$							
BT1240-CE	12	0,5	40	17	12	18	8	0,041	
BT1447-CE	14								
BT1654-CE	16	1,2	58	22	15	28,5	13	0,092	
BT1865-CE	18								
BT2069-CE	20	2,0	69	27	19	32,5	15	0,161	
BT2478-CE	24	2,5	78	32	23	34	18	0,249	
BT30103-CE	30	4,0	101	41	28	48	22	0,550	
BT36125-CE	36	6,3	125	49	35	60,5	27	0,955	
BT42145-CE	42	10,0	145	54	40	71	32	1,202	
BT52195-CE	52	12,5	195	67	50	100	40	2,464	

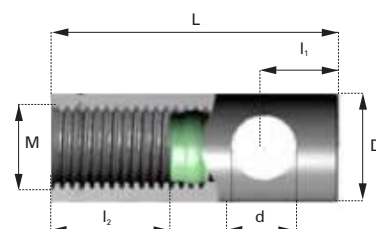

Lifting sockets

		Boccola ad onda		Wave socket					
Zinc. elettr.	Filetto	Carico	d	L	D	l ₁	l ₂	Peso	
Electr.Galv.	Threaded	Load Group	mm	mm	mm	mm	mm	Kg/pz	Weight
	Rd	$f_{cu} > 15 \text{N/mm}^2$							
TGK-M12-108	12	0,5	8	108	17	45	18	0,084	
TGK-M16-167	16	1,2	12	167	22	58	25	0,230	
TGK-M20-187	20	2,0	14	187	27	76	34	0,373	
TGK-M24-240	24	2,5	16	240	32	87	40	0,618	
TGK-M24-360	24	2,5	16	360	32	87	40	0,809	
TGK-M30-300	30	4,0	20	300	39	101	52	1,112	
TGK-M30-240	30	4,0	20	420	39	101	52	1,401	
TGK-M36-380	36	6,3	25	380	48	119	56	2,161	
TGK-M42-450	42	8,0	28	450	54	153	65	3,327	
TGK-M42-500	42	8,0	28	500	54	153	65	3,569	

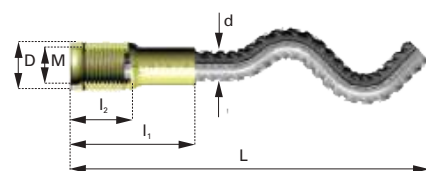

		Boccola ad onda lunga		Long wave socket					
Zinc. elettr.	Filetto	Carico	d	L	D	l ₁	l ₂	Peso	
Electr.Galv.	Threaded	Load Group	mm	mm	mm	mm	mm	Kg/pz	Weight
	Rd	$f_{cu} > 15 \text{N/mm}^2$							
TGL-M12-137	12	0,5	8	137	17	45	18	0,095	
TGL-M16-216	16	1,2	12	216	22	58	25	0,276	
TGL-M20-257	20	2,0	14	257	27	76	34	0,458	
TGL-M24-360	24	2,5	16	360	32	87	40	0,809	
TGL-M24-1000	24	2,5	16	1000	32	87	40	1,826	
TGL-M30-450	30	4,0	20	450	39	101	52	1,483	
TGL-M36-570	36	6,3	25	570	48	119	56	2,893	
TGL-M42-620	42	8,0	28	620	54	153	65	4,150	

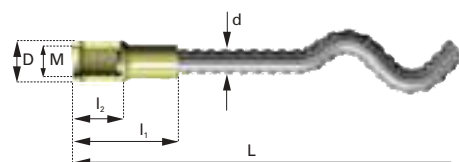

Tutti i tipi di boccole sono disponibili a richiesta con passo metrico M

All the sockets are available upon request with metric pacing

		Boccola dritta		Straight socket				
Zincata elettrol. Electr.Galv.	Filetto Threaded	Carico Load Group	d	L	D	l ₁	l ₂	Peso Weight
	Rd	f _{cu} >15N/mm ² t	mm	mm	mm	mm	mm	Kg/pz
TRL-MRd12-116	12	0,5	8	116	17	45	18	0,084
TRL-MRd12-144	12	0,5	8	144	17	45	18	0,095
TRL-MRd16-178	16	1,2	12	178	22	58	25	0,230
TRL-MRd16-230	16	1,2	12	230	22	58	25	0,276
TRL-MRd20-170	20	2,0	14	170	27	76	34	0,337
TRL-MRd20-200	20	2,0	14	200	27	76	34	0,373
TRL-MRd20-270	20	2,0	14	270	27	76	34	0,458
TRL-MRd24-257	24	2,5	16	257	32	87	40	0,618
TRL-MRd24-376	24	2,5	16	376	32	87	40	0,809
TRL-MRd24-1012	24	2,5	16	1012	32	87	40	1,826
TRL-MRd30-319	30	4,0	20	319	39	101	52	1,112
TRL-MRd30-436	30	4,0	20	436	39	101	52	1,401
TRL-MRd30-469	30	4,0	20	469	39	101	52	1,483
TRL-MRd36-402	36	6,3	25	402	48	119	56	2,161
TRL-MRd36-592	36	6,3	25	592	48	119	56	2,892

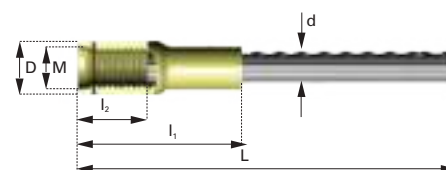

		Boccola chiodo		Anchor socket				
Zincata elettrol. Electr.Galv.	Filetto Threaded	Carico Load Group	d	L	D	l ₁	l ₂	Peso Weight
	Rd	f _{cu} >15N/mm ² t	mm	mm	mm	mm	mm	Kg/pz
HBS-MRd12-70	12	1,3	10	70	17	45	25	0,083
HBS-MRd12-130	12	1,3	10	130	17	45	25	0,120
HBS-MRd16-090	16	2,5	14	90	22	58	30	0,194
HBS-MRd16-140	16	2,5	14	140	22	58	30	0,254
HBS-MRd16-200	16	2,5	14	200	22	58	30	0,327
HBS-MRd20-125	20	4,0	18	125	27	74	37,5	0,401
HBS-MRd20-258	20	4,0	18	258	27	74	37,5	0,667
HBS-MRd24-140	24	5,0	20	140	32	87	45,5	0,581
HBS-MRd24-325	24	5,0	20	325	32	87	45,5	1,038
HBS-MRd30-185	30	7,5	24	185	39	101	56	1,044
HBS-MRd30-400	30	7,5	24	400	39	101	56	1,807
HBS-MRd36-475	36	10,0	28	475	47	131	66,5	3,054
HBS-MRd42-550	42	12,5	34	550	54	153	78	4,976
HBS-MRd52-575	52	15,0	34	575	68	189	97,5	6,335

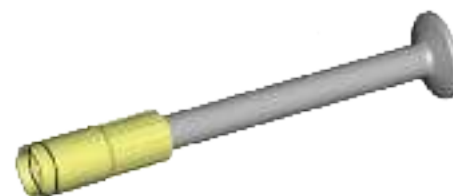
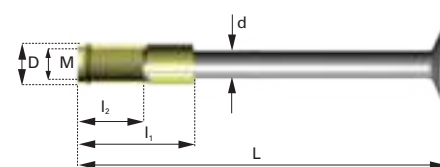

Tutti i tipi di boccole sono disponibili a richiesta con passo metrico M

All the sockets are available upon request with metric pacing

Boccola bullone Bolt anchor socket									
Zincata elettrol. Electr. Galv.	Filetto Threaded	Carico sollevamento Lifting load	Carico di fissaggio Fixing load		L	I	D	Vite Screw	Peso Weight
	M	t	B25 t	B45 t	mm	mm	mm	M	Kg/pz
HBB M12-90-TV	12	0,75	1,8	2,6	90	23	16	12x60	0,103
HBB M12-100-TV	12	0,75	1,8	2,6	100	23	16	12x70	0,112
HBB M12-150-TV	12	0,75	1,8	2,6	150	23	16	12x120	0,156
HBB M16-140-TV	16	1,5	2,7	4,6	140	30	22	16x100	0,280
HBB M16-220-TV	16	1,5	2,7	4,6	220	30	22	16x180	0,406
HBB M20-140-TV	20	2,0	3,7	5,0	140	38	26	20x90	0,431
HBB M20-150-TV	20	2,0	3,7	5,0	150	38	26	20x100	0,456
HBB M20-180-TV	20	2,0	3,7	5,0	180	38	26	20x130	0,530
HBB M20-270-TV	20	2,0	3,7	5,0	270	38	26	20x220	0,752
HBB M24-200-TV	24	3,0	5,8	7,8	200	45	32	24x140	0,881
HBB M24-320-TV	24	3,0	6,0	10,9	320	45	32	24x260	1,307
HBB M30-240-TV	30	5,0	7,6	10,2	240	60	40	30x160	1,655
HBB M30-380-TV	30	5,0	10,2	18,3	380	60	40	30x300	2,432
HBB M36-300-TV	36	7,0	10,6	14,3	300	78	47,5	36x200	2,881
HBB M36-420-TV	36	7,0	14,5	24,5	420	78	47,5	36x320	3,839
HBB M42-300-TV	42	10,0	10,5	14,0	300	64	54	42x210	4,184
HBB M42-460-TV	42	10,0	20,5	28,0	460	64	54	42x270	5,934

 Vite a testa esagonale
 zincata elettrolitica classe 8.8

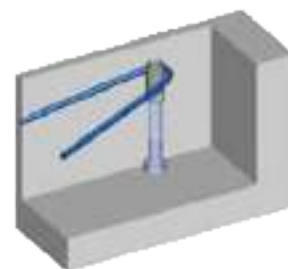
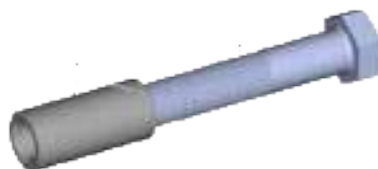
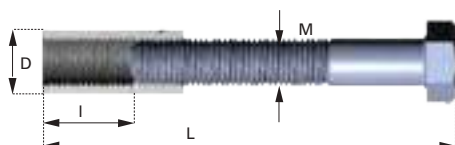
 Hexagonal headed bolt electrolytic
 galvanized - class 8.8

Tappo per Boccole Plastic nailing for socket					
Codice Code	Filetto Threaded	S	D	d	Peso Weight
	M	mm	mm	mm	Kg/pz
KU-10-M12-BR	12	10	55	45	0,018
KU-10-M16-BR	16	10	55	45	0,019
KU-10-M18-BR	18	10	55	45	0,020
KU-10-M20-BR	20	10	55	45	0,020
KU-10-M24-BR	24	10	55	45	0,024
KU-10-M30-BR	30	10	70	60	0,034

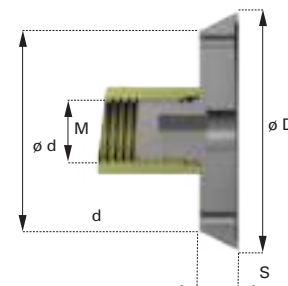

Asole flessibili per boccole BT-MAN Flexible slot for sockets						
Nera Black	Filetto Threaded	Carico Lifting load	e	l	H	Peso Weight
	Rd	kN	mm	mm	mm	Kg/pz
BT-MAN-12	12	9	22	32	155	0,08
BT-MAN-16	16	17	27	40	155	0,17
BT-MAN-20	20	32	35	50	215	0,33
BT-MAN-24	24	39	44	60	255	0,57
BT-MAN-30	30	50	55	85	300	1,29
BT-MAN-36	36	79	68	90	340	1,91
BT-MAN-42	42	102	75	100	425	2,69
BT-MAN-52	52	175	95	110	550	5,03

Tutti i tipi di boccole sono disponibili a richiesta con passo metrico M

All the sockets are available upon request with metric pacing

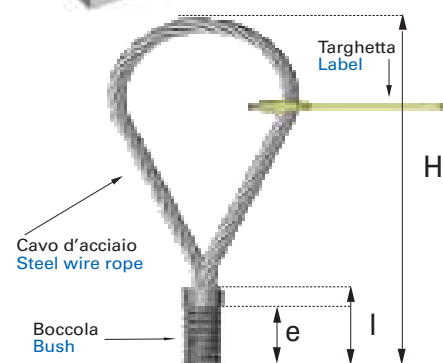
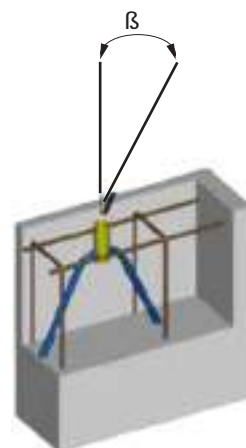

Cappio flessibile Loop							
Nero Black	Carico Lifting load	Cavo d'acciaio Wire rope		Dimensioni Dimentions		L	Peso Weight
	$f_{cu} > 15N/mm^2$	diam mm	lung mm	f mm	e mm	mm	Kg/pz
BT-TIL-008	0,8	6	540	60	150	210	0,12
BT-TIL-012	1,2	7	570	65	160	225	0,16
BT-TIL-016	1,6	8	615	70	165	235	0,22
BT-TIL-020	2,0	9	690	75	200	275	0,32
BT-TIL-025	2,5	10	780	85	230	315	0,44
BT-TIL-040	4,0	12	860	100	240	340	0,69
BT-TIL-052	5,2	14	1010	100	260	360	0,99
BT-TIL-063	6,3	16	1100	110	280	390	1,41
BT-TIL-080	8,0	18	1250	120	320	440	2,08
BT-TIL-010	10,0	20	1350	135	390	525	3,01
BT-TIL-125	12,5	22	1500	150	420	570	3,90
BT-TIL-160	16,0	26	1650	165	450	615	6,05
BT-TIL-200	20,0	28	1900	180	550	730	8,00
BT-TIL-250	25,0	32	2000	200	600	800	11,28
BT-TIL-320	32,0	36	2225	220	550	770	13,40
BT-TIL-370	37,0	36	2500	275	675	950	15,90
BT-TIL-470	47,0	44	3000	320	780	1100	28,20
BT-TIL-520	52,0	44	3350	350	850	1200	31,05

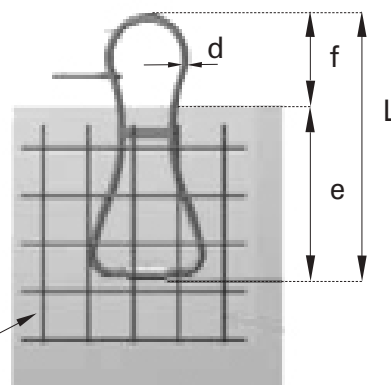
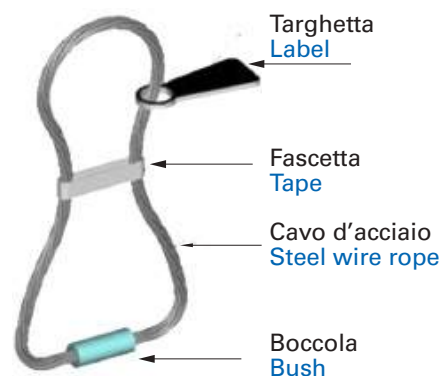

Armatura a carico dell'utilizzatore
Fabric or cage reinforcement

PSA e TSE
PSA and TSE

Connessione		PSA		Reinforcement coupler				Peso
Nera Black		Filetto Threaded		Barra di rinforzo Steel bar				Weight
L	A	B	d	Trazione Tensile	ø			
mm	M	mm	mm	mm	kN	mm ²	Kg/pz	
PSA-10-400	400	12	18	380	10	39,25	78,5	0,27
PSA-10-450	450	12	18	430	10	39,25	78,5	0,30
PSA-10-500	500	12	18	480	10	39,25	78,5	0,32
PSA-12-400	400	12	25	375	12	56,50	113	0,44
PSA-12-600	600	12	25	575	12	56,50	113	0,60
PSA-12-800	800	12	25	775	12	56,50	113	0,77
PSA-12-1500	1500	12	25	1475	12	56,50	113	1,44
PSA-12-400	400	16	25	375	12	56,50	113	0,44
PSA-12-410	410	16	25	385	12	56,50	113	0,44
PSA-12-600	600	16	25	575	12	56,50	113	0,60
PSA-12-800	800	16	25	775	12	56,50	113	0,77
PSA-12-1000	1000	16	25	975	12	56,50	113	0,98
PSA-12-1500	1500	16	25	1475	12	56,50	113	1,44
PSA-16-400	400	20	38	362	16	100,50	201	0,80
PSA-16-500	550	20	38	512	16	100,50	201	1,00
PSA-16-565	565	20	38	527	16	100,50	201	1,05
PSA-16-650	650	20	38	612	16	100,50	201	1,18
PSA-16-800	800	20	38	762	16	100,50	201	1,37
PSA-16-1020	1020	20	38	982	16	100,50	201	1,65
PSA-16-1440	1440	20	38	1402	16	100,50	201	2,44
PSA-20-700	700	24	42	658	20	157,00	314	2,00
PSA-20-715	715	24	42	673	20	157,00	314	2,02
PSA-20-800	800	24	42	758	20	157,00	314	2,25
PSA-20-1000	1000	24	42	958	20	157,00	314	2,65
PSA-20-1280	1280	24	42	1238	20	157,00	314	6,70
PSA-20-1800	1800	24	42	1758	20	157,00	314	9,70
PSA-20-2000	2000	24	42	1958	20	157,00	314	10,80
PSA-20-2200	2200	24	42	2158	20	157,00	314	11,85
PSA-20-4025	4025	24	42	3967	20	157,00	314	23,23
PSA-25-500	500	30	52	448	25	245,50	491	2,33
PSA-25-600	600	30	52	548	25	245,50	491	2,73
PSA-25-700	700	30	52	648	25	245,50	491	3,13
PSA-25-1000	1000	30	52	948	25	245,50	491	4,18
PSA-25-1050	1050	30	52	998	25	245,50	491	4,44
PSA-25-1500	1500	30	52	1448	25	245,50	491	6,15
PSA-25-2260	2260	30	52	2208	25	245,50	491	9,12

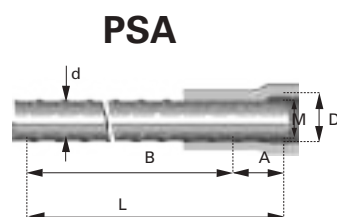

Ø Area nominale
 Ø Rated section

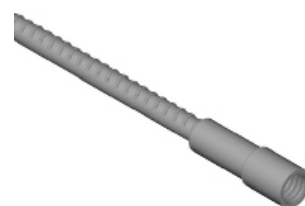

Barre in acciaio
 B500B

Steel bars B500B

Barra filettata PSA Reinforcement coupler								
Nere Black	Filetto Threaded		Barra di rinforzo Steel bar			Peso Weight		
L mm	M	A mm	B mm	d mm	Ø mm ²	Kg/pz		
PSA-32-1000	1000	42	65	935	32	401,90	803,8	7,32
PSA-32-1400	1400	42	65	1335	32	401,90	803,8	9,28
PSA-32-2300	2300	42	65	2235	32	401,90	803,8	15,13
PSA-40-1000	1000	48	72	928	40	625,00	1250	11,50
PSA-40-1250	1250	48	72	1178	40	625,00	1250	14,00
PSA-40-1500	1500	48	72	1428	40	625,00	1250	16,50
PSA-40-2000	2000	48	72	1928	40	625,00	1250	21,42

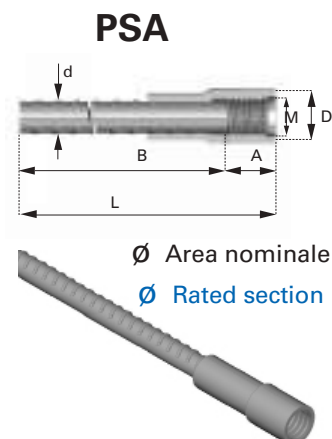

Barra filettata TSE Reinforcement coupler							
Nere Black	L	Filetto Threaded		Trazione Tensil		Peso Weight	
L mm	M	A mm	d mm	kN	Ø mm ²	Kg/pz	
TSE-12-200	200	16	min 22	12	56,5	113	0,200
TSE-12-372	372	16	min 22	12	56,5	113	0,370
TSE-12-575	575	16	min 22	12	56,5	113	0,550
TSE-12-800	800	16	min 22	12	56,5	113	0,755
TSE-12-1000	1000	16	min 22	12	56,5	113	0,940
TSE-12-1500	1500	16	min 22	12	56,5	113	1,400
TSE-12-2000	2000	16	min 22	12	56,5	113	1,850
TSE-16-200	200	20	min 28	16	100,5	201	0,344
TSE-16-520	520	20	min 28	16	100,5	201	0,845
TSE-16-770	770	20	min 28	16	100,5	201	1,240
TSE-16-1020	1020	20	min 28	16	100,5	201	1,635
TSE-16-1250	1250	20	min 28	16	100,5	201	2,000
TSE-16-1440	1440	20	min 28	16	100,5	201	2,300
TSE-16-2200	2200	20	min 28	16	100,5	201	3,500
TSE-16-3500	3500	20	min 28	16	100,5	201	5,630
TSE-20-200	200	24	min 35	20	157,0	314	0,540
TSE-20-665	665	24	min 35	20	157,0	314	1,670
TSE-20-965	965	24	min 35	20	157,0	314	2,410
TSE-20-1280	1280	24	min 35	20	157,0	314	3,190
TSE-20-1800	1800	24	min 35	20	157,0	314	4,475
TSE-20-2200	2200	24	min 35	20	157,0	314	5,460
TSE-25-1000	1000	30	min 43	25	245,5	491	3,925
TSE-25-1500	1500	30	min 43	25	245,5	491	5,855
TSE-25-2260	2260	30	min 43	25	245,5	491	8,700
TSE-32-1000	1000	42	min 45	32	401,9	803,8	6,520
TSE-32-1400	1400	42	min 45	32	401,9	803,8	9,010
TSE-32-2300	2300	42	min 45	32	401,9	803,8	14,700

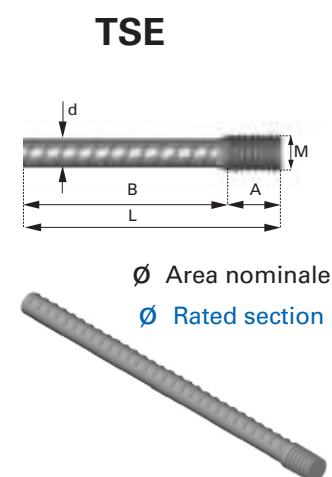

Barre in acciaio
 B500B

Steel bars B500B

Scatole di ripresa con ferri **Steel connection box**

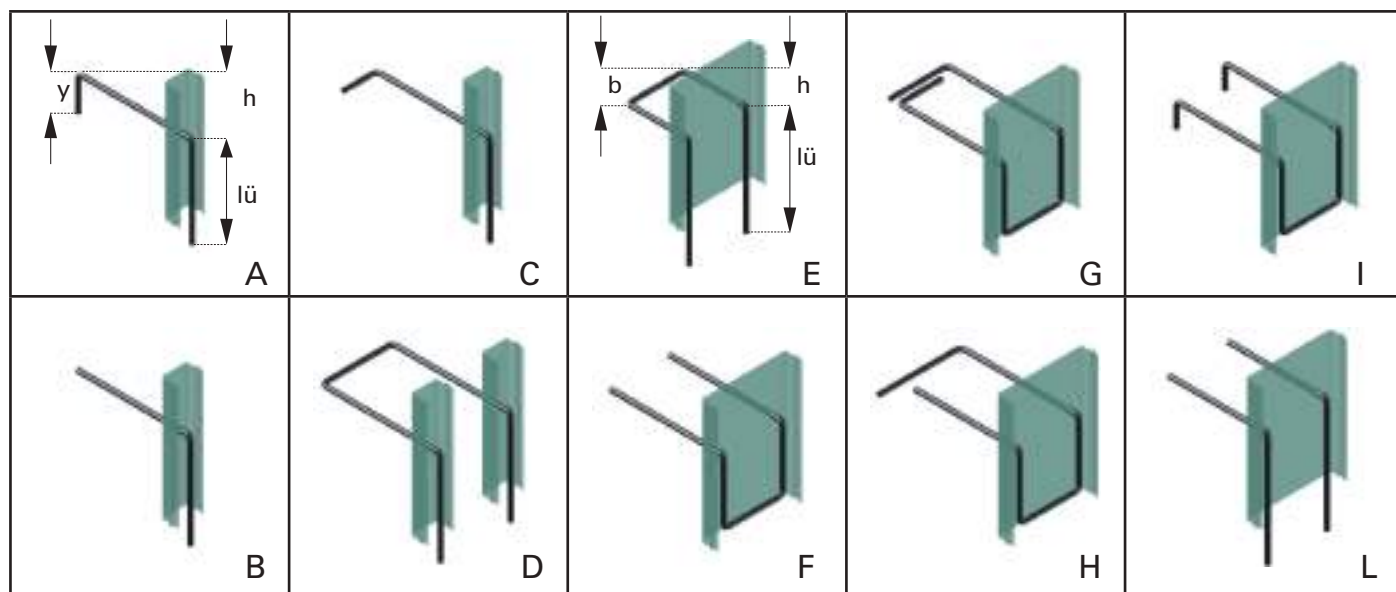
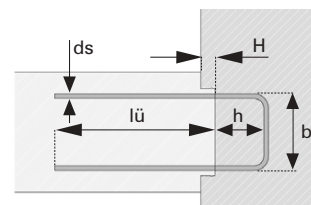

Scatole di ripresa con cappi **Loops connection box**

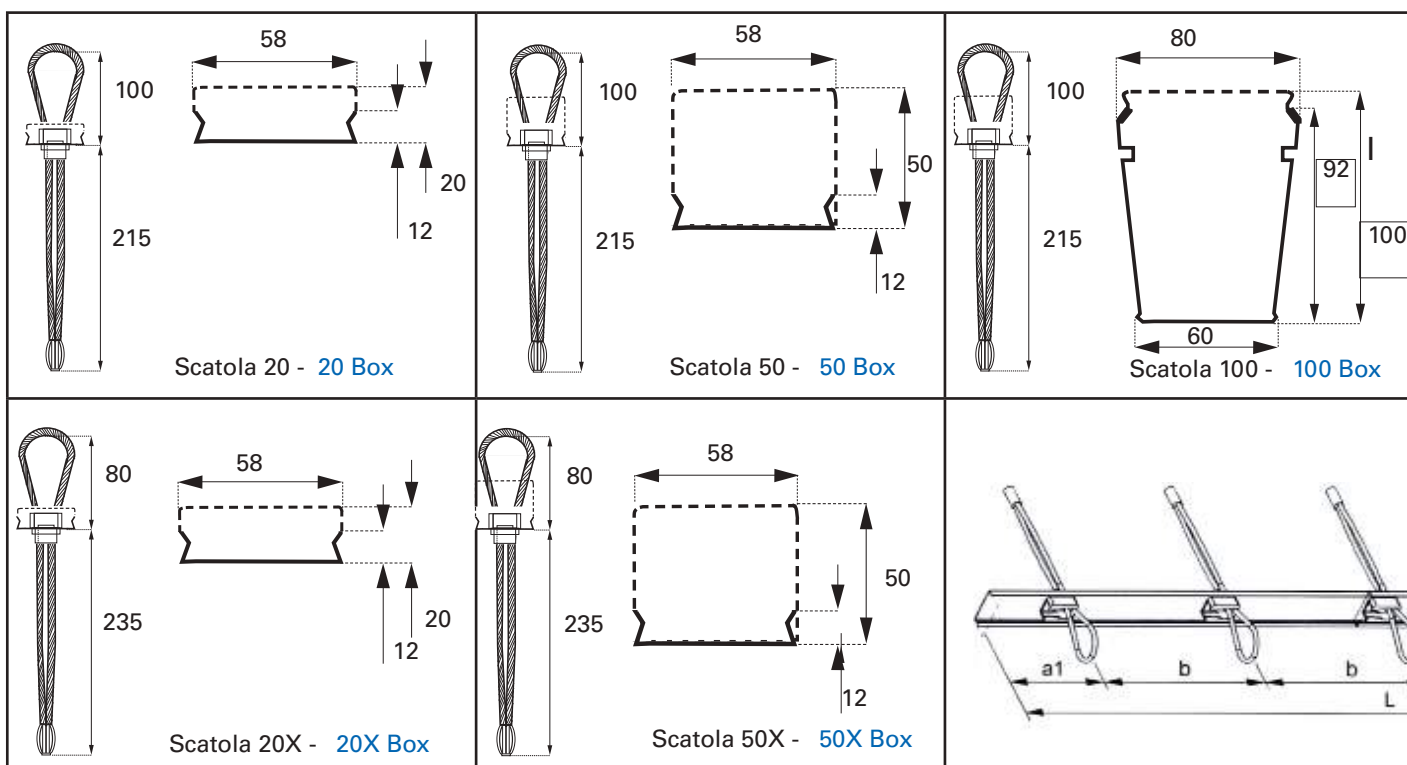
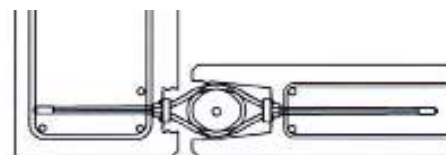

Referenze

Fondazione Feltrinelli - Milano - Italia

Architetti Herzog & De Meuron

- 1 Struttura prefabbricata - [Precast structure](#)
- 3 Scorcio da Porta Volta - [Porta Volta view](#)

References

Feltrinelli - Milan - Italy

Herzog & De Meuron Architects

- 2 Elementi strutturali - [Structural elements](#)
- 4 Elementi strutturali - [Structural elements](#)
- 5 Ancoraggio del rivestimento - [Facade anchorage](#)

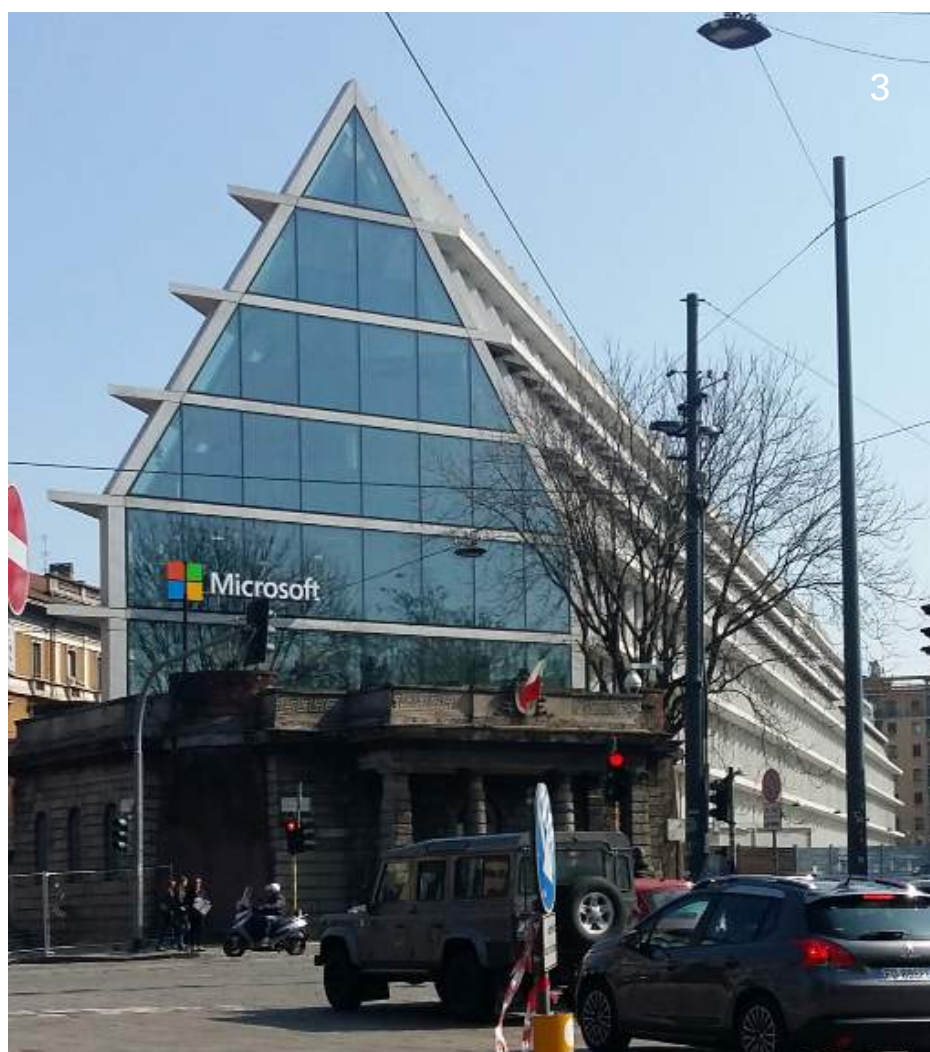

1 Banca San Paolo - Torino - Italy
4 Nestlè - Milano - Italy



2 Torre Cajasol - Sevilla - Spain
5 Gae Aulenti Square - Milano - Italy



3 Bosco verticale - Milano - Italy



Reinforcing box





GL LOCATELLI s.r.l.

Via Dante Alighieri, 66
22078 Turate (CO) - Italy
tel +39 02 9648 07 21
fax +39 02 968 27 95

gl@gllocatelli.it
www.adermalocatelli.it